

Human Generated Power for Mobile Electronics*

Thad Starner

GVU Center, College of Computing
Georgia Tech
Atlanta, GA 30332-0280

Joseph A. Paradiso

Responsive Environments Group, Media Laboratory
MIT
Cambridge, MA 02139

1 Introduction

Since the 1990's, mobile computing has transformed its penetration from niche markets and early prototypes to ubiquity. Personal Digital Assistants (PDAs) evolved from GRiD's PalmPad and Apple's Newton in 1993 to the Palm, Handspring, and Microsoft-based models that support the multi-billion dollar industry today. While BellSouth/IBM's Simon may have been the only mobile phone to offer e-mail connectivity in 1994, almost every modern mobile phone provides data services today. Portable digital music players have replaced cassette and CD-based systems, and these "MP3 players" are evolving into portable repositories for music videos, movies, photos, and personal information such as e-mail. Laptops, which were massive and inconvenient briefcase devices in the late 1980's, now outsell desktops. Yet all these devices still have a common, difficult problem to overcome: power.

This chapter will review trends in mobile computing over the past decade and describe how batteries affect design tradeoffs for mobile device manufacturers. This analysis leads to an interesting question: is there an alternative to batteries? Although the answer has many components that range from power management through energy storage [142], the bulk of this chapter will overview the history and state-of-the-art in harvesting power from the user to support body-worn mobile electronics.

2 Technology Trends in Mobile Computing

Mobile phone companies often sell more batteries than phones to consumers. The phones sold to users include a rechargeable battery so that the device is immediately useful, but a certain number of consumers are expected to own more than one battery during the life of their phone. The same can probably be said for laptops and camcorders. Yet, there is little incentive for consumers to buy new batteries except for when they fail or when the consumer feels the need for a larger battery. Unlike other areas of mobile computing that benefit from exponential improvements in performance, battery energy density (as measured by joules per kilogram or joules per cubic centimeter) changes slowly so that there is little pressure for consumers to upgrade.

2.1 Battery Energy Density as a Lagging Trend

As Figure 1 shows, battery energy is one of the most laggard trends in mobile computing. Figure 1 shows the progression of technology in the last 13 years for laptop computers, a technology now mostly mature. In general, the laptop technology represented in the graphs would, if repackaged in a body worn device, weigh seven pounds or less and could be used while standing on a street corner in a major United States city. While some mobile computers existed prior to 1990, most weighed over 10 pounds or did not include hard drives. In addition, commercial wireless data networks in the United States were not openly available before 1990 or required amateur radio licenses to operate.

The graph depicts increases in performance as multiples of the state of the technology from 1990 (e.g. the amount of RAM available in a laptop increased by 256X from 1990 to 2003). Due to the exponential nature of the improvements, the y-axis in Figure 1 is on a logarithmic scale.

* to appear in Piguet, T. (Ed), *Low Power Electronics Design*, CRC Press, Fall 2004.

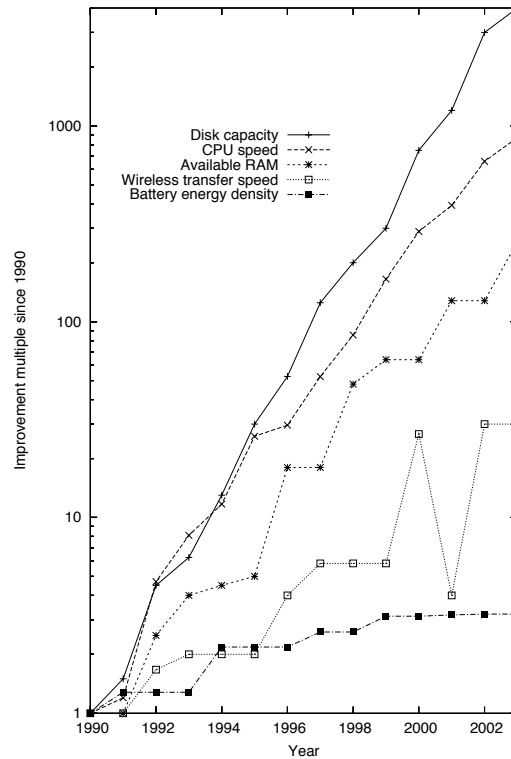

Figure 1: Improvements in mobile computing technology from 1990-2003. Note that the wireless connectivity curve considers only cellular standards; not short-range 802.11 “hotspots”.

The laptop specifications shown were determined by examining advertisements in the December issues of popular computing magazines (e.g. *Byte*, *PC Computing*, etc.) for each year. The numbers used reflect a composite from the highest-end machines available at that time. An example of a high-end machine from 1990 (the base value of 1 in the graph) would be a 16MHz 80386 with 8 megabytes (MB) of RAM and 40MB of hard drive space using a nickel-cadmium battery and communicating at 4800 baud over the ARDIS network. Processor performance is compared in terms of Intel’s *iCOMP*® index as derived from www.cpuscorecard.com; RAM and disk storage are compared by size; wireless networks are compared by maximum bits per second of data transfer; and battery energy density is determined by the type of technology used (nickel cadmium, nickel metal hydride, or lithium ion) and the progression these technologies made in increasing the joules stored per kilogram (J/kg). The wireless connectivity graph represents the first author’s pursuit of the commercial city-wide networks available in the United States (cellular standards; not emerging 802.11 “hotspots”).

While disk storage density has increased over 4000X since 1990, the lowly battery has only increased a factor of three in energy density. New materials, along with nano and micro fabrication technologies, have recently enabled “micro fuel cells” [145] aimed at recharging handhelds like cell phones with power plants the size of a small candy bar [177], and eventually powering wireless sensor nodes with fuel cells on a chip [163, 102, 120]. Although the technology is rapidly advancing [60], laptop-sized plants (e.g., 30-50 W-hr), have tended to be in an awkward place for fuel cells - too big to directly power with micro cells, but small enough that the overhead in mass needed to handle the standard fuel cell chemistry is significant (not to mention safety factors associated with the fuel, high expense of the platinum membrane, etc.). Nonetheless, several companies have announced prototypes designed for laptops [32], which should make it to market over the next couple of years and gradually improve. More exotic emerging power technologies tend to have characteristics that force them into niche applications - e.g., radioactive batteries [81] can last for decades, but provide very little current, while devices that actually burn fuel [3], such as microturbines [63] and microengines [72], have potential issues with safety and byproducts like exhaust, heat, noise, or thrust.

The lesson to mobile device designers is clear: specify the battery or power source first, then design the mobile device’s electronics around it. Battery technology is the least likely element to change in the 12 month development cycle and may be

the most limiting factor in the design with respect to size, weight, and cost.

2.2 Trading Storage and Processing for Wireless Connectivity

Wireless connectivity is also a conundrum for mobile designers. While the designer can control the CPU, RAM, disk, and battery in his device, wireless connectivity is often provided by another party. In the extreme case, a wireless provider may go out of business and significantly impact the quality of service that can be expected. Such a situation is reflected in Figure 1 where the removal of the Metricom network reduced the maximum available throughput from 128,000 bits per second to 19,200 in several major U.S. markets.

Even on a minute-by-minute basis, a wireless connection may or may not be available at any given moment. The device designer must either cache information for the user or refuse service when the network is not available [107]. Thus, many devices, such as wireless PDAs, have non-volatile RAM or disks so that the user can work “off-line.” Using mass storage strategically can save significantly on battery consumption, as both receiving and transmitting data from cellular and 802.11 networks require substantial power [174]. More specifically, the power needed for transmitting is proportional to the distance to the fourth power [47]. Given the exponential trends in disk density above, it may soon be a viable power-saving strategy to cache a good fraction of static Internet content for a mobile web surfer instead of connecting over power-hungry and potentially expensive wireless networks! One can imagine a system that examines the user’s e-mail, web history, and downloads and, based on this data, continuously updates the user’s mobile cache while the device has wired (or low power) connectivity.

An interesting illustration of this point is to compare the power required to retrieve information from modern flash memory with the power required to transmit a request of that information from a remote source. Suppose that we have the option of storing information on a cellular phone in the form of a flash disk or sending a wireless request for the information to the network. Reading a bit from modern flash memory requires approximately 10 pJ or 1×10^{-11} J/bit [13]. However, transmitting a single bit at 0.6W from a mobile phone at an aggressive 1 Mbps rate would require 6×10^{-7} J. Thus, for every bit transmitted in the wireless request for information, the same amount of energy could be used to read 60,000 bits from a flash drive. This calculation is conservative as it ignores the inefficiencies in the radio, the overhead generally associated with transmission error checking, and the amount of power that would be required to receive, process, and store the response from the network. Thus, a mobile device designer should always consider how much information can be stored or cached on the device itself as opposed to depending on wireless services.

The sensor network community is very concerned with a similar tradeoff - i.e., how much data to process locally at a sensor node vs. how much data to wirelessly transmit. As it takes between 100 and 10000 times more power to transmit one bit across even a short range than to execute a single processor instruction (depending on the implementation) [153], it’s often advantageous to analyze and/or compress the node’s data before broadcasting [151]. In order to reduce the node’s power requirements down to the point where ambient energy harvesting is practical, researchers are pursuing joint optimization of the processor hardware, radio circuitry, and network protocols [132]. Although we do not explicitly consider the amount of power required to receive the information, this is often not negligible, especially in short-range networks, where it can take more power to receive and decode a bit than to transmit one [153].

3 Power from Incident Radiation

3.1 Catching the Ambience

With so many RF transmitters of various sorts distributed throughout today’s urban environments, one might consider background RF as a potential power reservoir for mobile devices. Electronic systems that harvest energy from ambient radiation sources, however, tend to be extremely power-limited and generally require a large collection area or need to be located very close to the radiating source. A classic example can be found in old-fashioned crystal radio kits [106] that draw their power directly from AM radio stations, which play audibly through high-impedance headphones without needing a local source of energy. The size of the required antenna, however, can be prohibitive for wearable applications unless the bearer is very close to a transmitter, and access to a good ground is usually required. Even so, the received power is very limited in a standard crystal radio, where set builders typically see received powers on the order of 10’s of μ W, approaching a milliwatt for proximate stations. An interesting adaptation of a crystal radio set is described in US Patent# 2,813,242 [56], where a resonant tank circuit tuned to a strong, nearby station provides enough power to run a single-transistor radio with a small loudspeaker that can be tuned to other stations. An analysis of RF power scavenging at higher frequencies by Yeatman [194] crudely approximates the power density produced by a receiving antenna as E^2/Z_0 , where Z_0 is the radiation resistance of

free space (377 Ohms). An electric field (E) of 10 V/m thus yields $26 \mu\text{W}/\text{cm}^2$ at the antenna. Field strengths of even a few volts per meter are rare in habitated environments, however, except when very close to a powerful transmitter [123]. In a related note, power can also be extracted from the earth, across a large ground loop, tapping the AC potential difference between grounds at different locations. A harvest of 1.4 mW has been reported using a pair of grounds separated by 50 feet [169].

An example of ambient RF power harvesting in the mobile sphere at higher frequency is found in aftermarket modules that flash LED's when your cell phone rings. Several of these designs are batteryless, but need to be extremely close (or right against) the cell phone's antenna to work, as they draw their energy through near-field capacitive or inductive coupling. Perhaps another mobility example, much further afield, comes from the strange, scattered and usually anecdotal reports of people receiving strong, nearby radio broadcasts from spontaneous detectors formed by loose fillings in their teeth [86, 40], and the passive, implantable receiver design that this has inspired [152, 7].

Higher up in the electromagnetic spectrum, it's not uncommon to see very low power consumer items, such as simple calculators, run off photovoltaics with ambient illumination. The energy conversion efficiency of easily available and relatively inexpensive crystalline silicon solar cell modules (without going to IC-grade silicon or stacked junction structures) is generally below 20%, and closer to 10% for flexible amorphous silicon panels [26]. Accordingly, mobile applications, which generally imply limited surface area, tend to be constrained, especially in scenarios without strong and consistent sunlight (standard solar cells produce roughly $100 \text{ mW}/\text{cm}^2$ in bright sun and $100 \mu\text{W}/\text{cm}^2$ in a typically illuminated office). Nonetheless, products like solar battery chargers for cell phones that purport to produce up to 2 Watts of power [117] and PDA's that run off a panel of solar cells lining their case [164] currently exist, and researchers continually strive to refine solar cell materials [92, 26] and technologies [27] to increase efficiency [78], as well as explore unusual form factors, such as flexible photovoltaic fibers [97], that promise to be more amenable to wearable implementations.

3.2 Get on the Beam

Rather than relying on the limited energy that can be scavenged from ambient radiation, other approaches actively beam power from a transmitter to remote devices. The wireless transfer of power originates with Heinrich Hertz who, ushering the dawn of radio in the late 1800's, induced sympathetic sparks across a gap interrupting a resonantly tuned ring placed several yards away from a transmitting antenna that was directed with a parabolic reflector [178]. The dream of wirelessly broadcasting power to an urban area dates back to the turn of the 20'th century and Nicola Tesla [180], who experimented with grandiose concepts of global resonance and gigantic step-up coils that radiated strong, 150 kHz electromagnetic fields able to illuminate gas-filled light bulbs attached to a local antenna and ground at large distances [50]. Wireless power research continued with the work of H.V. Noble [38], who in the early 30's at the Westinghouse Laboratory, demonstrated the transfer of several hundred watts between 100 kHz antennas separated by 25 feet, leading to public demonstrations of this technology at the Chicago World's Fair in 1933. The development of radar [39], hence powerful microwave transmitters, enabled further work in directed energy transmission, a highlight of which was the wireless powering of a small helicopter by William C. Brown in 1964 [38]. Microwave-to-DC converters, termed "rectannas" can be extremely efficient; efficiencies of over 90% have been produced in laboratory experiments and 30 kilowatts have been transferred across more than a mile at 84% efficiency [38]. This has led to proposals for beaming massive amounts of power to earth from solar collectors in space [75] and remotely beaming propulsion to interstellar probes from an earth-orbiting 10 gigawatt transmitter [69].

Closer to home, FCC and safety regulations (e.g., IEEE/ANSI C95.1) along with public perception [70] have restricted the beaming of any significant amount of power in the proximity of people. Nonetheless, researchers have experimented with microwave transmission of power in domestic environments, transferring several mW across meters to sensors for ubiquitous and wearable computing applications [19]. At much lower power levels, short-range wireless power transmission is now commonplace in passive Radio Frequency Identification (RFID) systems [65], which derive their energy inductively, capacitively, or radiatively from the tag reader. As most RFID chips talk back to the reader by dynamically changing their impedance or reflection coefficient, they require minimal power, generally between 1 and $100 \mu\text{W}$, depending on their implementation and operating frequency (lower-frequency, magnetically-coupled tags consume less power). Today, people commonly carry RFID transponders, most often for keyless entry systems. Simple resonant RF tags that change their tuned frequency or Q as a function of a local or environmental parameter have been used as passive sensors in several applications [155, 99]. Examples include LC (inductive-capacitive) tags for wireless displacement and pressure sensors in human-computer interfaces [143], measuring tire inflation with pressure-varying backscatter from crystal bulk resonators [24], tracking tire strain with surface-acoustic wave (SAW) devices [149], and proposed studies for using such SAW sensors as implantable blood pressure monitors [129].

The reverse, where people carry the reader to interrogate tags in the environment, is not as feasible, since the readers tend to be power hungry and large (e.g., several orders of magnitude more massive than the tags). Researchers, however, in wearable and ubiquitous computing have adapted reader circuits to identify tagged objects when handled with reader-integrated gloves [165, 146] or put into coil-lined pockets [94], and small, single-chip readers are now becoming available by companies like EM Microelectronic and Innovision Research & Technology for very short-range, lower-power applications [6].

4 Power from the People

Potentially, there is a way around the limitations of batteries and the very restricted amount of energy available to siphon off common ambient environments: scavenge power from the user [175]. The human body is a tremendous storehouse of energy. Just one gram of fat stores nine dietary Calories, which is equivalent to 9000 calories or

$$\left(\frac{9,000\text{calories}}{1g_{fat}}\right)\left(\frac{4.19J}{\text{calorie}}\right) = 37,700J \text{ per gram of fat}$$

An average person of 68 kg (150 lbs) with 15% body fat stores energy approximately equivalent to

$$0.15(68kg)\left(\frac{1,000g}{1kg}\right)\left(\frac{37,700J}{1g_{fat}}\right) = 384MJ$$

Thus, if even a small fraction of this stored energy could be scavenged, a mobile device would have a large and renewable resource to draw upon. That said, the devil is in the details. Although researchers are working to develop in-vivo fuel cells [105] that oxidize blood glucose to provide a very small trickle of energy (circa a milliwatt) to power low duty-cycle implants (e.g., a valve to aid incontinence, efficient biomedical sensors, or low-power transmitters for tracking animals) [29, 157], tapping directly into the biological processes that turn fat into energy is beyond currently available technology. On the other hand, power might be scavenged indirectly from the user's everyday actions or might be intentionally generated by the user. Indeed, products (flashlights, radios, watches, etc.) have been on the market for years that operate in this mode, and researchers are driven to leverage other devices into this niche, while finding alternative ways to tap excess energy from human activity [104, 54]. Table 1 provides a perspective on the amount of power used by the human body during various activities. Everyday human activity consumes power at a rate of 81-1630W, a factor of 20 in energy use. Bearing in mind that any technique that parasitically harvests background energy from unrelated human activity must be totally unobtrusive to be commonly adopted, perhaps a couple of watts might be scavenged somewhere for a mobile phone or on-body computer without putting an onerous load on the user. The following sections examine this possibility with respect to power recovery from body heat, breathing, blood pressure, typing, arm motion, pedaling, and walking. A summary of the potentially scavengable power and the total power from various body-centered actions is provided in Figure 2. Note, however, that energy harvested from the user may require considerable conditioning (storage, voltage/current or impedance conversion, etc.) before it can be used for an application. Although we touch on a few important issues in conditioning power for piezoelectric generators, Chapter 7 of Edgar Callaway's "Wireless Sensor Networks" [44] provides an introduction to this topic specific to energy harvesting systems, and several other references on power conditioning are provided for the reader's convenience [46, 140].

5 Hot Bodies: Power from Body Heat

Since the human body emits energy as heat, it follows naturally to try to harness this energy. However, Carnot efficiency puts an upper limit on how well this waste heat can be recovered. Assuming normal body temperature and a relatively low room temperature (20° C), the Carnot efficiency is

$$\frac{T_{body} - T_{ambient}}{T_{body}} = \frac{(310K - 293K)}{310K} = 5.5\%$$

In a warmer environment (27° C) the Carnot efficiency drops to

$$\frac{T_{body} - T_{ambient}}{T_{body}} = \frac{(310K - 300K)}{310K} = 3.2\%$$

Table 1: Human energy expenditures for selected activities. Derived from [137].

<i>Activity</i>	<i>Kilocal/hr</i>	<i>Watts</i>
sleeping	70	81
lying quietly	80	93
sitting	100	116
standing at ease	110	128
conversation	110	128
eating meal	110	128
strolling	140	163
driving car	140	163
playing violin or piano	140	163
housekeeping	150	175
carpentry	230	268
hiking, 4 mph	350	407
swimming	500	582
mountain climbing	600	698
long distance run	900	1,048
sprinting	1,400	1,630

This calculation provides an ideal value. Today’s thermoelectric generators that might harness this energy do not approach Carnot efficiency in energy conversion. Although work on new materials [68] [186] and new approaches to thermoelectrics [82, 58] promise to somewhat improve conversion efficiencies, today’s standard thermopiles are 0.2% to 0.8% efficient for temperature differences of five to 20°C [176], as expected for a wearable system in temperate environments. For the sake of discussion, the theoretical Carnot limit will be used in the analysis below, hence the numbers are optimistic.

Table 1 indicates that while sitting, a total of 116 W of power is available. Using a Carnot engine to model the recoverable energy yields 3.7-6.4 W of power. In more extreme temperature differences, higher efficiencies may be achieved, but robbing the user of heat in adverse environmental temperatures is not practical.

Evaporative heat loss from humans account for 25% of their total heat dissipation (basal, non-sweating) even under the best of conditions. This “insensible perspiration” consists of water diffusing through the skin, sweat glands keeping the skin of the palms and soles pliable, and the expulsion of water-saturated air from the lungs [73]. Thus, the maximum power available without trying to reclaim heat expended by the latent heat of vaporization drops to 2.8-4.8 W.

The above efficiencies assume that all of the heat radiated by the body is captured and perfectly transformed into power. However, such a system would encapsulate the user in something similar to a wetsuit. The reduced temperature at the location of the heat exchanger would cause the body to restrict blood flow to that area [73]. When the skin surface encounters cold air, a rapid constriction of the blood vessels in the skin allows the skin temperature to approach the temperature of the interface so that heat exchange is reduced. This self-regulation causes the location of the heat pump to become the coolest part of the body, further diminishing the returns of the Carnot engine unless a wetsuit is employed as part of the design.

While a full wetsuit or even a torso body suit is unsuitable for many applications, the neck offers a good location for a tight seal, access to major centers of blood flow, and easy removal by the user. The neck is approximately 1/15 of the surface area of the “core” region (those parts that the body tries to keep warm at all times). As a rough estimate, assuming even heat dissipation over the body, a maximum of 0.20-0.32 W could be recovered conveniently by such a neck brace. The head may also be a convenient heat source for some applications where protective hoods are already in place - the head is also a very convenient spot for coupling sensory input to the user. The surface area of the head is approximately three times that of the neck and could provide 0.60-0.96 W of power given optimal conversion. Even so, the practicality, comfort, and efficacy of such a system are relatively limited.

Even given all the limitations mentioned above, practical body-worn, thermally-powered systems have been created. The Seiko *Thermic*[®] wristwatch uses 10 thermoelectric modules to generate sufficient μ W to run its mechanical clock movement from the small thermal gradient provided by body heat over ambient temperature [100]. While this commercial example is recent, the idea was articulated in 1978 in US Patent #4106279 [126]) with variations reflected in later patents [66, 67]. Given the commercial production of such thermogenerative systems, one can imagine small on-body sensor networks

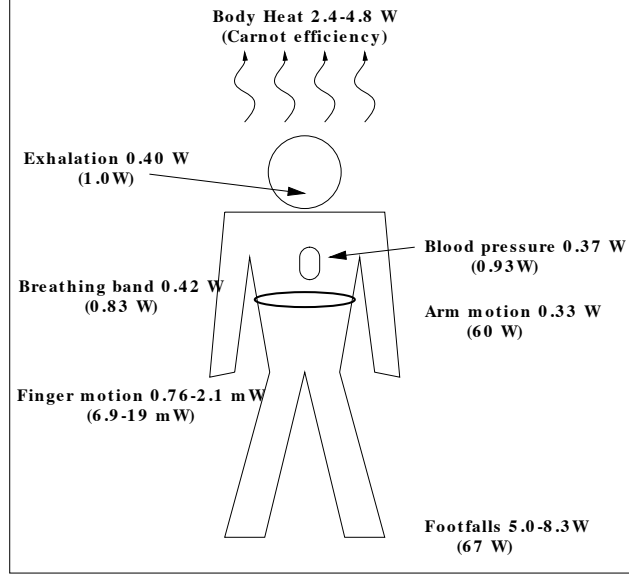

Figure 2: Possible power recovery from body-centered sources. Total power for each action is included in parentheses.

working on the same principle. These systems can store power during periods of higher ΔT in order to continue to run during periods of warmer ambient temperatures. In addition, such storage may be useful for communicating sensor readings, perhaps from a medical device, in bursts to some central server. Indeed, such a product has been recently announced by Applied Digital Solutions as the “Thermo Life Generator”, a half-square-centimeter thermoelectric device claimed to be capable of generating $10 \mu\text{W}$ or more at 3 volts when in contact with the body [145].

6 Heavy Breathing: Power from Respiration

An average person of 68 kg has an approximate air intake rate of 30 liters per minute [137]. However, available breath pressure is only 2% above atmospheric pressure [192, 147]. Studies indicate that the power consumed by pulmonary ventilation (breathing) is between 0.1 and 40 Watts [53]. Increasing the effort required for intake of breath may have adverse physiological effects [147] so only exhalation will be considered for generation of energy. Thus, the maximum available power is

$$W = p\Delta V = 0.02 \left(\frac{1.013 \times 10^5 \text{ kg}}{\text{m} \cdot \text{sec}^2} \right) \left(\frac{30 \text{ l}}{1 \text{ min}} \right) \left(\frac{1 \text{ min}}{60 \text{ sec}} \right) \left(\frac{1 \text{ m}^3}{1,000 \text{ l}} \right) = 1.0 \text{ W}$$

During sleep, the breathing rate, and therefore the available power, may drop in half, while increased activity increases the breathing rate. Forcing an elevated breath pressure with an aircraft-style pressure mask can increase the available power by a factor of 2.5, but it causes significant stress on the user [73].

For some professionals such as military aircraft pilots, astronauts, or handlers of hazardous materials, such masks are already in place. However, the efficiency of a turbine and generator combination is only about 40% [84], and any attempt to tap this energy source would provide additional load on the user. Thus, the benefit of the estimated 0.40 W of recoverable power has to be weighed against the other, more convenient methods discussed in the following sections.

Another way to generate power from breathing is to fasten a tight band around the chest of the user. From empirical measurements, there is a 2.5 cm change in chest circumference when breathing normally and up to a 5 cm change when breathing deeply. A large amount of force can be maintained over this interval. Assuming a respiration rate of 10 breaths per minute and an ambitious 100 N force applied over the maximal 0.05 m distance, the total power that can be generated is

$$(100 \text{ N})(0.05 \text{ m}) \left(\frac{10 \text{ breaths}}{1 \text{ min}} \right) \left(\frac{1 \text{ min}}{60 \text{ sec}} \right) = 0.83 \text{ W}$$

A ratchet and flywheel or a stretchable dielectric elastomer generator (see Sections 10 and 12.2) attached to an elastic band around the chest might be used to recover this energy. However, friction due to the small size of the parts may cause some energy loss. With careful design, a significant fraction of this power might be recovered, but the resulting 0.42 W is a relatively small amount of power for the inconvenience.

While such a chest band may at first seem inappropriate, some popular breath and heart rate monitors sold as exercise equipment use similar chest bands for their sensors. Interestingly, the idea of using a chest band for recovering power from the user is quite old. Chapuis reports a similar mechanism for winding watches in the historical record from the 1600's [48].

Researchers have explored tapping the energy of breathing for powering implantable electronics; in vivo animal tests of a piezoelectric foil laminate that's bonded to a pair of ribs that stretch the foil during breathing have generated 17 μ W in a dog, and with improvements claim to be able to attain 1 mW [87].

7 And the Beat Goes On: Power from Blood Pressure

While powering electronics with blood pressure may seem impractical, the numbers are actually quite surprising. Assuming an average blood pressure of 100 mm of Hg (normal desired blood pressure is 120/80 above atmospheric pressure), a resting heart rate of 60 beats per minute, and a heart stroke volume of 70 ml passing through the aorta per beat [31], then the power generated is

$$(100\text{mm Hg})\left(\frac{1.013\times 10^5\text{kg/m}\cdot\text{sec}^2}{760\text{mm Hg}}\right)\left(\frac{60\text{beats}}{1\text{min}}\right)\left(\frac{1\text{min}}{60\text{sec}}\right)\left(\frac{0.07\text{l}}{\text{beat}}\right)\left(\frac{1\text{m}^3}{1,000\text{l}}\right) = 0.93\text{W}$$

While this energy rate can easily double when running, harnessing this power is difficult. Adding a turbine to the system would increase the load on the heart, perhaps dangerously so. However, even if 2% of this power is harnessed, low power microprocessors and sensors could run. Thus, self-powering medical sensors and prostheses could be created. Ramsay and Clark [154] performed a design study on a variant of this idea using blood pressure to drive a piezoelectric generator (more details on piezoelectric generators are provided below). Their results indicate that a generator using a square centimeter of piezoelectric material should be capable of providing power on the level of μ W continuously and mW intermittently.

8 Shaking It Up: Power from Inertial Microsystems

Capturing enough energy from vibrations to power sensors and telemetry has a long history in vehicles, where considerable mechanical excitation is usually available. In the patent literature, one can find techniques ranging from linear motor generators with bouncing spring-mounted magnet arrays for use in trucks and trains [181] to piezoelectric generators embedded in tires and wheels for monitoring air pressure and tire conditions [172, 184, 109]. Similarly, purely mechanical devices exist that scavenge energy from dynamics - for example, a self-powered hour meter that integrates time when it is exposed to vibration from sources like operating machine tools [16].

In the world of mobility, pocket watches and wristwatches, in some senses the precursors to wearable computers, addressed the issue of mechanical power scavenging with the advent of the self-winding watch. These watches use the motion of the user's body during walking ("pedometer" watches) or the motion of the user's arm during everyday actions to wind their mechanisms. The first known self-winding pedometer watch was created circa 1770 by Abraham-Louis Perrelet, though there are indications that earlier watches may have been made in the 1600's [48]. However, widespread adoption of these systems did not occur until after the 1930's when watch cases could be hermetically sealed to protect the mechanism from dust.

Taking apart a modern self-winding wristwatch reveals a 2 gram "proof" mass mounted off-center on a spindle. As the user moves during the day, the mass rotates on the spindle and winds the mechanism. A simple variant would use the same off center mass design except that the mass would be a magnet. As the magnet spins past coils of wire mounted in the sides of the watch, it induces an electrical current that can be used to run low power electronics.

An electrical version of this concept has proven successful in the form of the ETA Autoquartz Self-Winding Electric Watch (see Figure 3) [74]. The proof mass winds a spring which, when enough mechanical energy is stored, drives a micro generator at its optimal rate of 15,000 rotations per minute (RPM). The generator is pulsed for 50 ms at a time, yielding 6 mA at greater than 16V. The generated power is stored in a capacitor for later use.

Another watch-sized electrical inertial generation system is the Seiko AGS [127]. This system provides a more direct connection from the proof mass to the generator and creates 5 μ W on average when the watch is worn and 1mW when the watch is forcibly shaken. The Seiko AGS system has been scaled up to provide a power source for sensors mounted on

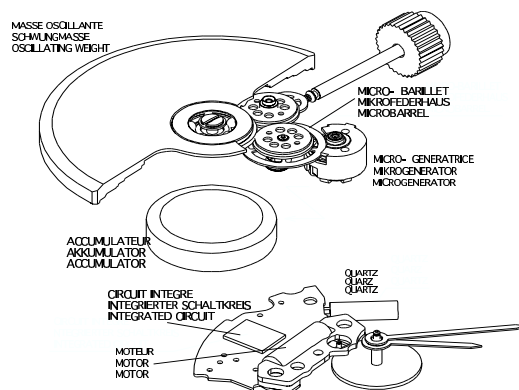

Figure 3: ETA Autoquartz Self-Winding Electric Watch. Image courtesy of the Swatch Group [74].

marine mammals. The idea is that some of the motion of the marine mammal will be recovered and converted to electrical power for the on-body system. This device, since it can be larger, generates 5–10mW of power in an approximately 5x5cm package. In a similar vein, LED Flashlights are on the market that power themselves through active shaking [185], which causes a proof-mass magnet to oscillate through a solenoidal coil, bouncing efficiently against rubber bumpers placed at each end. We have tested the generating mechanism of one of these products - weighing 150 grams, it was capable of generating 200 mW with a steady shake at its mechanical resonance (roughly 200 cycles/minute).

Inertial power generators do not have to be limited to systems that are handheld or mounted on the wrist. At the International Symposium on Wearable Computers (ISWC) in 2003, von Büren, Lukowicz, and Tröster at ETH in Zurich theorized a similar approach for passive excitation using a spring-mounted one gram mass [41]. Their experiments showed that up to $200\mu\text{W}$ of power can be parasitically generated due to the vibrations of the mass while the user walks.

Meanwhile, several compact vibration-based microgenerators are appearing in the sensors and actuators literature; Mitcheson and colleagues give an excellent review in [134]. Several of these are compact magnetic generators based on small, sub-cm structures with moving magnets or coils, similar in concept to a phonograph cartridge. Accordingly, Ching et al. have manufactured 1 cm^3 micro-spring Faraday generators that generate $830\mu\text{W}$ at a constant vibration of 60–100Hz at an amplitude of approximately $200\mu\text{m}$ [51], while James et al. [98] have built a similar, but somewhat larger device that generates over a milliwatt at these excitation frequencies and El-Hami et al. [62] have built a 240 mm^3 magnetic generator that surpasses a milliwatt at 320 Hz. Such devices have begun entering the commercial realm with products such as the Energy Harvester from Ferro Solutions in Cambridge MA, which claims to obtain an energy density of $120\mu\text{W}$ per cubic centimeter from 100mG vibrations at 21 Hz (power output scales quadratically with acceleration) or 20mG vibration at 21 Hz (generates 0.4 mW from their 75-cm^3 generator) [5, 156].

Taking another tack, Roundy and collaborators have developed a compact piezoelectric generator from a tip-loaded, cantilevered beam made from a pair of laminated PZT strips to form a bimorph that produces nearly $100\mu\text{W}$ when shaken at resonance [159, 161, 145]. In an application closer to wearables, a small piezoelectric, tip-loaded cantilever was proposed for powering bioelectric implants back in 1967; a prototype device was claimed to have produced $150\mu\text{W}$ when mechanically coupled to 80 Hz heartbeats [108]. Piezoelectric-based, vibration-driven generators are now reaching the commercial market through products like the Harvester package from Continuum Control [156].

Other projects proceed to the MEMS scale with variable-capacitance electrostatic generators [131, 133, 160]. Unlike magnetic and piezoelectric generators, electrostatic generators need to be “bootstrapped” with an external power source (e.g., a battery) that applies an initial voltage across the device’s capacitance before it begins producing power. As these devices tend to be quite small, they are designed to be driven at frequencies ranging from hundreds of Hz to several kHz and, depending on their excitation and power conditioning, typically yield on the order of $10\mu\text{W}$, hence are intended to support extremely low power applications, perhaps sited on the same chip as the generator. While these excitation frequencies cannot be commonly expected when mounted on the human body, some energy is produced in these regions from shocks or rapid motion (perhaps frequency-translated by introduced mechanical nonlinearity).

Some researchers have exploited larger electrostatic generators with highly resonant mechanical coupling to work at lower frequencies. Miyazaki [136] and collaborators have used a 45-Hz electrostatic generator with a Q of 30 to extract hundreds of nanowatts from micron-level wall vibrations, while Tashiro and collaborators [179] derived $58\mu\text{W}$ from such a device

resonating at 4.76 Hz with the aim of parasitically exploiting body motion to power biomedical implants. This aim has been also pursued by Görge, Kirstein, and Erbel, who describe initial experiments of using inertial electrical generators for powering pacemakers. Their systems generated only 1–10% of the necessary power during normal office work, but they indicate that their systems have not yet been optimized in weight, orientation, and efficiency [77]. Because environmental vibration, especially from human motion, can occur over a range of generally lower frequencies, Mitcheson and collaborators have developed an electrostatic generator using a non-resonant snap-action restoring force on the proof mass instead of a continuous spring; laboratory prototypes have yielded 0.3 μJ of energy per mechanical cycle [135].

Vibration-driven microgenerators would allow for small, wireless, self-powered sensors that could be distributed on the body. By simply reporting the amount of vibration of the mass, these devices can act as a crude accelerometer. Applications could include systems that monitor the tremors of Parkinson’s patients for better diagnosis and adjustment of medical dosage [189], gesture recognition systems, sports devices such as pedometers, and devices that monitor activities of daily living for older adults with Alzheimer’s or with high risk of stroke or heart disease. Signals from small cantilevered piezoelectric sensors can be large enough to selectively activate electronics in deep sleep when stimulated by typical human motion, enabling highly efficient, hybrid battery-powered systems that quiescently take essentially no current, but passively “wake up” when subject to an impulse above a certain level [64].

9 Power Typing

Keyboards will continue to be a major interface for computers into the next decade [173]. As such, typing may provide a useful source of energy. On a one-handed chording keyboard (HandyKey’s *Twiddler*®), it is necessary to apply 130 grams of pressure in order to depress a key the required 1 mm for it to register. Thus,

$$\left(\frac{0.13\text{kg}}{\text{keystroke}}\right)\left(\frac{9.8\text{m}}{\text{sec}^2}\right)(0.001\text{m}) = 1.3\text{mJ per keystroke}$$

is necessary to type. Assuming a moderately skilled typist (40 wpm [122]), and taking into account multiple keystroke combinations, an average of

$$\left(\frac{1.3\text{mJ}}{\text{keystroke}}\right)\left(\frac{5.3\text{keystrokes}}{\text{sec}}\right) = 6.9\text{mW}$$

of power is generated. A fast QWERTY typist (90 wpm) depresses 7.5 keys per second. A typical keyboard requires 40-50 grams of pressure to depress a key the 0.5 cm necessary to register a keystroke (measured on a DEC PC 433 DX LP). Thus, a QWERTY typist may generate

$$\left(\frac{0.05\text{kg}}{\text{keystroke}}\right)\left(\frac{9.8\text{m}}{\text{sec}^2}\right)(0.005\text{m})\left(\frac{7.5\text{keystrokes}}{\text{sec}}\right) = 19\text{mW}$$

of power. Unfortunately, neither method provides enough continuous power to sustain a portable computer, especially since the user would not be continuously typing on the keyboard. However, there may be enough energy in each keystroke for each key to “announce” its character to a nearby receiver.

Self-powered buttons are not a new idea. Zenith televisions in the 1950’s featured a self-powered remote control where a button, when pressed, would strike one of several tuned aluminum rods that resonated at ultrasonic frequencies [1]. This sound pulse was decoded at the TV, which changed channels appropriately. Paradiso and Feldmeier took this theme further by using a piezoelectric element with resonantly-matched transformer and conditioning electronics that, when struck by a button, generates approximately 0.5 mJ at 3V per 15N push, enough power to run a digital encoder and a radio that can transmit up to 50 feet [141]. This innovation enables compact digital controllers (for example, a light switch) to be placed freely, without needing any wiring or batteries and their associated maintenance. A recent working prototype of this device is shown in Figure 4. Another version of a self-powered piezoelectric radio button has recently been marketed in Germany by a company called EnOcean, an affiliate of Siemens [148, 195], which uses a bistable piezoelectric cantilever that snaps when pressed and released, conditioned by a switching regulator. We have seen this device produce about 100 μJ per 8N push at 3.3 Volts.

Another option, potentially feasible for keyboards, is to make a keyboard with permanent magnets in its base. Each key would then have an embedded coil that would generate a current when the key was pressed. This concept was presented by the authors in 1996 [175] and appears in United States patent #5,911,529 [55].

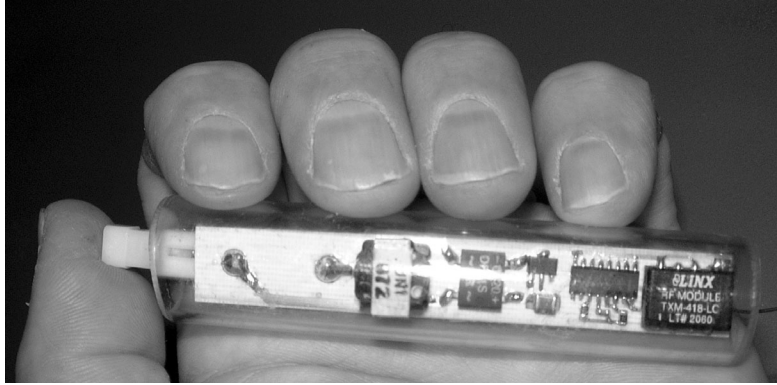

Figure 4: The MIT Self-Powered Wireless Button: power generated from piezoelectric element transmits a digital RF code after a single push.

One can imagine other on-body input devices communicating wirelessly using power scavenged from the user's actions. For example, a finger or wrist-mounted trackball could be "self-powered." Moving the trackball would turn the wheel encoders inside the device, both registering the movement and powering the device.

10 Hand Waving: Power from Arm Motion

While finger motion might allow for powering buttons or keyboards, intentional arm motion might generate enough power for notebook computing. The comparison of the activities listed in Table 1 indicates that violin playing and housekeeping use up to 30 kcal/hr, or

$$\frac{30kcal}{1hr} \left(\frac{4.19J}{1calorie} \right) \left(\frac{1hr}{3,600sec} \right) = 35W$$

more power than standing. Most of this power is generated by moving the upper limbs. Empirical studies done at the turn of the century show that for a particular 58.7 kg man, the lower arm plus hand masses 1.4 kg, the upper arm 1.8 kg, and the whole arm 3.2 kg [30]. The distance through which the center of mass of the lower arm moves for a full bicep curl is 0.335 m, while raising the arm fully over the head moves the center of mass of the whole arm 0.725 m. Empirically, bicep curls can be performed at a maximum rate of 2 curls/sec and lifting the arms above the head at 1.3 lifts/sec. Thus, the maximum power generated by bicep curls is

$$(1.8kg) \left(\frac{9.8m}{sec^2} \right) (0.335m) \left(\frac{2curls}{sec} \right) (2arms) = 24W$$

while the maximum power consumed by arm lifts is

$$(3.2kg) \left(\frac{9.8m}{sec^2} \right) (0.725m) \left(\frac{1.3lifts}{sec} \right) (2arms) = 60W$$

Obviously, housekeeping and violin playing do not involve as much strenuous activity as these experiments. However, these calculations do show that there is plenty of energy to be recovered from an active user. The task at hand, then, is to recover a useful amount of energy without burdening the user. A much more reasonable number, even for a user in an enthusiastic gestural conversation, is attained by dividing the bicep curl power by a factor of eight. Thus, the user might make one arm gesture every two seconds. This activity, then, generates a total of 3 W of power. By doubling the normal load on the user's arms and mounting a pulley system on the belt, 1.5 W might be recovered (assuming 50% efficiency from loss due to friction and the small parts involved), but the system would be extremely inconvenient.

Driving the generators via an arm-fitting exoskeleton may be a slightly better approach, although still very bulky and uncomfortable for common use. A somewhat less encumbering variant might involve mounted pulley systems in the elbows of a jacket. The take-up reel of the pulley system could be spring-loaded so as to counter-balance the weight of the user's arm. Thus, the system would generate power from the change in potential energy of the arm on the downstroke and not require

additional energy by the user on the upstroke. The energy generation system, the CPU, and the interface devices could be incorporated into the jacket. Thus, the user would simply don his jacket to use his computer. However, any pulley or piston generation system would involve many inconvenient moving parts and the addition of significant mass to the user.

A more innovative solution would be to use electroactive materials at the joints which would generate current when pushed or pulled via the movement of the user. Thus, no moving parts per se would be involved, and the jacket would not be significantly heavier than a normal jacket. One might naively think that piezoelectric polymers (e.g., PVDF) would be a candidate material - as outlined in the last section, piezoelectric foils need to be pulled along their most sensitive axis to generate charge, and as the maximum effective strain supported by such a foil is of order 1-2%, this would lead to a rather stiff arm. Piezoelectrics bonded to stiffer structural members in bridges, buildings, or aircraft, however, are able to achieve sufficient strain to generate some energy - researchers at Sandia National Laboratories [4] and MicroStrain Corporation [52, 156], for example, have developed such strain-based energy harvesters for powering logging monitors and wireless sensor nodes mounted on large structures subject to flex and vibration.

Another option would be to squeeze dielectric elastomers [144, 20] - these are soft, rubbery, compliant materials, capable of supporting 50-100% area strain, that are sandwiched between the plates of a capacitor. As a charged dielectric elastomer is compressed and released, the voltage across the capacitor changes in proportion to the capacitance shift, producing power. As the power scales with the square of the voltage across the capacitor plates, several thousand volts (typically 1-6 kV) are applied to these devices - in response, a full compression/expansion cycle can produce well over a Joule of energy. Dielectric elastomers (sometimes called electroactive polymers) are discussed further in the section on extracting energy from heel strikes (Section 12.2), to which they are well suited.

A more practical solution of having the user deliberately impart energy that's stored in the device can be seen in consumer items. Wind-up magnetic generators housed with flashlights have been around since the beginning of the 20'th century [57, 121]; their descendant, the shake-driven flashlight, was introduced earlier, in Section 10. More recently, radios designed by South African inventor Trevor Baylis and sold by Freeplay and Radio Shack allow the user to wind them up and thereby store enough power for 30-60 minutes of operation [104, 96]. In a typical windup radio, 60 turns (1 min of cranking) stores 500 Joules of energy in a spring, which drives a magnetic generator that's 40% efficient [95], metering out enough power for up to an hour of play (magnetic generators with efficiencies better than 90% are available, but are much too expensive for such a mass-market product). Using a wind-up system, the mobile user can spend some directed effort at generating and storing power for a mobile computer or phone followed by a period of use of the device, either eliminating the battery (by storing energy in a spring) or charging it [21]. Indeed, windup cell phone chargers have become standard items - a collaboration between Motorola and Freeplay resulted in the "Freecharge", a cigarette-pack sized generator that, after cranking for 45 seconds, allows a 4-5 minute phone call [54, 12], while Innovative Technologies produces the even smaller "SideWinder"; weighing under 80 grams and featuring a side-mounted crank, it provides over 6 minutes of talk time after 2 minutes of cranking [15]. Japan-based Nissho Engineering has produced innovative hand-cranked generators for many years under the brand name "Aladdin"[14]. Nissho's "AladdinPower" is a handheld electromagnetic generator with a lever that one cranks by squeezing; it produces 1.6 watts of power when the handle is squeezed at 90 times per minute, and was built for general applications that include charging cell phones or running flashlights. Nissho's Tug Power series of generators operate in a different mode - it takes a similar cigarette-pack form factor and weighs 80 grams, but here one grabs a finger ring and repeatedly pulls a spring-return cord extending from the bottom of the unit. As energy is stored in a flywheel that drives the generator, and the arm motion involved in pulling is less strenuous than hand cranking, this device produces more power; the manufacturer rates it at 2.5 watts. Saul Griffith of the MIT Media Lab has designed another kind of power source with string attached, but coming from Australia, he took inspiration from the "bull roarer", an indigenous, musical wind instrument attached to a length of rope which a player whips around their head. Saul's device, termed a "Bettery" [79], employs a small cushioned ball tethered to a hand-held generator. By revolving this 100-200 gram proof mass around on a .3-.5 meter long string, the generator turns at a 1-2 Hz rotation rate, and 3-5 Watts are produced [80]. Most test subjects felt comfortable swinging the Battery for up to 2-4 minutes. The user needs to be surrounded by a clear region of 1-2 meters, however, to avoid hitting objects and other people with the ball. Taking a similar direction, the "ReGen" design study explores embedding a wireless MP3 player and magnetic generator into a yo-yo, claiming that a dozen vigorous tosses can provide up to an hour of continuous music play [23].

Although most laptops would require over an hour of cranking to achieve a reasonable charge, the concept of wind-up portable computers has been around for a while [101], and demonstrated by Carnegie-Mellon University (CMU) by making a wind-up generator for their 1W StrongArm-based wearable computer called the Metronaut [170].

11 Pedal power

Manually-cranked electronics were common in the 1940's with shortwave radios taken into the Australian outback. Soldiers and adventurers needed a way of communicating with the rest of the world without the support of an electrical grid. Accordingly, companies began making miniature bicycle pedal arrangements, similar to those sold in today's gadget magazines for under-the-office-desk exercising, to generate power for the user's two-way shortwave radio. Up to 60W can be obtained in this manner. As the legs tend to be stronger and more enduring than the arms, and since legs also naturally project the force of the body's weight, generators pumped by leg motion are an ideal way to obtain more power through deliberate action. Today, the electronics in some fitness club exercise bicycles are powered by the user's actions, and it's not unusual to see personal computers powered by stationary bicycles in developing regions like rural India and Laos [18]. In fact, some Indian schools combine physical education with computer class; one half of the students bicycle to provide the power for the other half's computers!

Other foot-driven generators aren't based on bicycles, but instead use a small, stationary pedal coupled to an embedded magnetic generator. A perfect example is the "Stepcharger" [14], also manufactured by Nissho Engineering, which can generate up to 6 Watts when the pedal is vigorously pumped. Concluding this section with a more whimsical example, an inventor named Henderson is reported to have developed hydraulically-driven generators powered by bladders that are placed onto roadways to scavenge power when run over by passing cars, on farms to glean power when stepped on by passing cattle, and on sidewalks to harness energy from the footsteps of pedestrians [162].

12 March of Dynes: Power from Walking

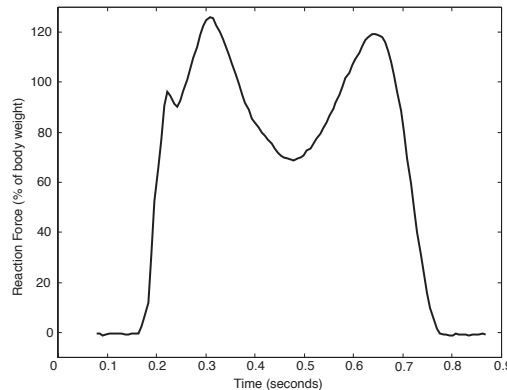

Figure 5: Empirical data taken for a healthy 52 kg woman, showing the time dependence of the vertical reaction force over a single footstep in a standard walk. The narrow spike at left is the "heel strike transient," caused by rapid flattening of the calcaneal fat pad. It is followed by the major force peaks occurring at heel down and just before toes off, which can exceed 120% of body weight. This curve is typical for human gait. Data courtesy of the Biomotion Laboratory at the Massachusetts General Hospital.

An obvious extension from pedal systems is to design a power recovery system for walking. Using the legs is one of the most energy consuming activities the human body performs. In fact, a 68 kg man walking at 3.5 mph, or 2 steps per second, uses 280 kcal/hr or 324 W of power [137]. Comparing this to standing or a strolling rate implies that up to half this power is being used for moving the legs. While walking, the traveler puts up to 30% more force on the balls of his feet than that provided by his body weight (Figure 5). However, calculating the power that can be generated by simply using the fall of the heel through 5 cm (the approximate vertical distance that a heel travels in the human gait [30]) reveals that

$$(68kg)\left(\frac{9.8m}{sec^2}\right)(0.05m)\left(\frac{2steps}{sec}\right) = 67W$$

of power is available. Even though walking is not continuous like breathing, some of the power could be stored, providing a constant power supply even when the user is not walking. The following sections outline the feasibility of harnessing this power via piezoelectric, electrostatic, and rotary generators.

The 67W result above is a truly maximum number, in that utilizing the full 5-cm stroke would result in significant additional load on the user (while creating a significant trip hazard); it is like continuously ascending a circa 5° grade, and would result in the feeling of “walking in sand”. Indeed, the body continually optimizes the gait to minimize energy expenditure in various types of ambulation [76] - any significant energy load must be limited and carefully extracted to avoid ambulatory fatigue or even podiatric injury after significant use. A 1-cm stroke, roughly the amount of deflection that one can see in a padded running shoe [168], can be considered as an upper practical limit that can be tolerated by general users [125], resulting in maximum of 13W available with full body weight applied. Even so, we continue to use a 5-cm stroke in the calculations that follow to determine a theoretically maximum power that might be obtained.

12.1 Piezoelectric materials

Piezoelectric materials create electrical charge when mechanically stressed. Among the natural materials with this property are quartz, human skin, and human bone, though the latter two have very low coupling efficiencies [25]. Table 2 shows properties of common industrial piezoelectric materials: polyvinylidene fluoride (PVDF) and lead zirconate titanate (PZT). For convenience, references for data sheets and several advanced treatments of piezoelectricity are included at the end of this chapter [8, 11, 43, 71, 93, 158, 61].

Table 2: Piezoelectric characteristics of PVDF and PZT (adapted from [8, 71, 9]).

<i>Property</i>	<i>Units</i>	<i>PVDF</i>	<i>PZT</i>
Density	$\frac{g}{cm^3}$	1.78	7.6
Relative permittivity	$\frac{\epsilon}{\epsilon_0}$	12	1,700
Elastic modulus	$\frac{10^{10} N}{m}$	0.3	4.9
Piezoelectric constant	$\frac{10^{-12} C}{N}$	$d_{31}=20$ $d_{33}=30$	$d_{31}=180$ $d_{33}=360$
Coupling constant	$\frac{CV}{Nm}$	0.11	$k_{31}=0.35$ $k_{33}=0.69$

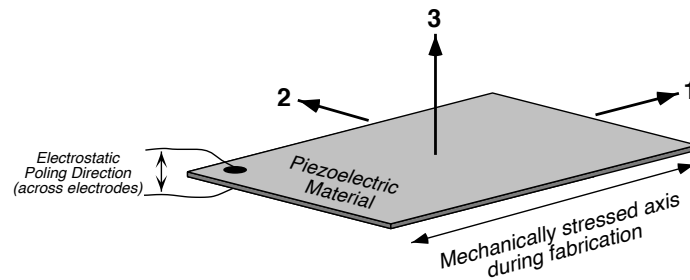

Figure 6: Definition of axes for piezoelectric materials. Note that the electrodes are mounted across the 3 axis.

The coupling constant shown in Table 2 is the efficiency with which a material converts mechanical energy to electrical. The subscripts on some of the constants indicate the direction or mode of the mechanical and electrical interactions (see Figure 6). The 3-axis surfaces are typically metallized (e.g., with sputtered aluminum, silver epoxy, or, incases of extreme strain, carbon) to facilitate electrical connection. “31 mode” indicates that strain is caused to axis 1 by electrical charge applied to axis 3. Conversely, strain on axis 1 will produce an electrical charge along axis 3, hence (since the device in Figure 6 forms a capacitor), pulling the piezo material along the 1 axis develops a voltage across the 3 axis. Bending elements, termed unimorphs (piezo material on one side of the element) and bimorphs (piezo material on both sides) exhibiting an expanding

upper layer and a contracting bottom layer, are commonly exploited in industry. In practice, such bending elements have an effective coupling constant of 75% of the theoretical due to storage of mechanical energy in the mount and shim center layer.

The most efficient energy conversion, as indicated by the coupling constants in Table 2, comes from compressing PZT (d_{33}). Even so, the amount of effective power that could be transferred this way is minimal since compression follows the formula

$$\Delta H = \frac{FH}{AY}$$

where F is force, H is the unloaded height, A is the area over which the force is applied, and Y is the elastic modulus. The elastic modulus for PZT is 4.9×10^{10} N/m². Thus, it would take an incredible force to compress the material a small amount. Since energy is defined as force through distance, the effective energy generated through direct human-powered compression of PZT would be vanishingly small, even with perfect conversion.

On the other hand, bending a piece of piezoelectric material to take advantage of its 31 mode is much easier. Because it is hard and brittle, unprocessed PZT does not have much range of motion in this direction. Maximum surface strain for this material is 5×10^{-4} . Surface strain can be defined as

$$S = \frac{xt}{L_c^2}$$

where x is the deflection, t is the thickness of the beam, and L_c is the cantilever length. Thus, the maximum deflection or bending for a beam (20 cm) of a piezoceramic thin sheet (0.002 cm) before failure is

$$x = \frac{(S)(L_c^2)}{t} = \frac{(5 \times 10^{-4})(0.2m)^2}{0.00002m} = 1cm$$

Thus, unprocessed PZT is unsuitable for jacket design or applications where flexibility is necessary, although a piezoceramic-laden composite is available [89] that offers a limited amount of flexibility.

PVDF, on the other hand, is very flexible. In addition, it is easy to handle and shape, exhibits good stability over time, and does not depolarize when subjected to very high alternating fields. The drawback, however, is that PVDF's coupling constant is significantly lower than PZT's. Also, shaping PVDF can reduce the effective coupling of mechanical and electrical energies due to edge effects. Furthermore, the material's efficiency degrades, depending on the operating climate and the number of plies used. In addition, as PVDF is compliant, one can not as easily exploit power transfer through a mechanical resonance, although the frequencies involved in walking are far below the natural frequencies of any reasonably-sized piece of PZT. Fortunately, from an industry representative [85], we know a 116 cm² 40 ply triangular plate with a center metal shim deflected 5 cm by 68 kg 3 times every 5 seconds results in the generation of 1.5 W of power, as developed for an application to harness energy from ocean waves [45]. This result is a perfect starting point for the calculations in the next section. For the newcomer to piezoelectric film, several basic articles on power generation with PVDF by Brown [33, 34, 35, 36, 37] are available from the website of Measurement Specialties (MSI), the prime manufacturer of piezoelectric PVDF.

12.2 Piezoelectric shoe inserts and elastomer heels

Consider using PVDF shoe inserts for recovering some of the power in the process of walking. There are many advantages to this tactic. First, a 40 ply pile would be only $(28 \mu m)(40) = 1.1$ mm thick (without electrodes). In addition, the natural flexing of the shoe when walking provides the necessary deflection for generating power from the piezoelectric pile. PVDF is easy to cut into an appropriate shape and is very durable [8, 71]. In fact, PVDF might be used as a direct replacement for normal shoe stiffeners. Thus, the inserts could be easily put into shoes without moving parts or seriously redesigning the shoe.

A small women's shoe has a footprint of approximately 116 cm². Knowing that the maximum effective force applied at the end of a user's step increases the apparent mass by up to 30%, the user needs only 52 kg (115 lbs) of mass to deflect the PVDF plate a full 5 cm. While the numbers given in the last section were for a 15.2 cm by 15.2 cm triangular 40 ply pile, these values can be used to approximate the amount of power an appropriately shaped piezoelectric insert could produce. Thus, scaling the previous 1.5 W at 0.6 deflections per second to 2 steps per second, these numbers indicate that

$$(1.5W) \left(\frac{2 \text{ steps/sec}}{0.6 \text{ steps/sec}} \right) = 5W$$

of electrical power could be generated by a 52 kg user at a brisk walking pace.

Such a considerable predicted power harvest is encouraging, but it was derived by ad-hoc normalization of results from the ocean-wave generator element, which potentially misses some important details of the insole implementation. A more accurate relation for such an insole that accounts for the displacement current delivered to a load from the strain of a bending piezoelectric element (or “stave”), has been derived by Toda [183] and adapted by Kendall [103]:

$$P_{peak} = \frac{(e_{31}AS_1\omega)^2R}{1 + \omega^2C^2R^2}$$

Where:

P_{peak} Peak power produced in Watts

e_{31} Piezo Stress Constant = $d_{31}Y$, where d_{31} is the Piezo Strain Constant and Y is Young’s Modulus

A Total area of the piezoelectric material (the area of the stave scaled by the number or piezoelectric layers)

ω Dominant angular frequency of excitation

R Load resistance

C Total capacitance of all piezoelectric layers (note that all layers are connected in parallel to minimize the stave impedance, and layers on opposite sides of the center need to be electrically reversed to account for the opposite strain, hence change in polarity).

S_1 Net strain along axis 1: $S_1 = \frac{h\Delta y}{(\frac{1}{2}L)^2}$

h Thickness of the stave

Δy Maximum bending deflection of the stave

L Length of stave along the bending direction (axis 1)

Plugging in the numbers above, together with an expected 3 μ F stave capacitance and a dominant frequency of roughly 5 Hz (as seen in waveforms taken with people walking on similar piezoelectric insoles [113]) and applying a matching load resistance that delivers the most power at this excitation frequency (note that this occurs when the denominator of the relation for P_{peak} is 2), we obtain $P_{peak} = 2.5$ Watts. Note the average power is about a factor of five lower than this, as a single-cycle, roughly sinusoidal, 5-Hz pulse is produced once per step per shoe in a standard 1-Hz per leg gait, yielding $\langle P \rangle = 250$ mW for one such shoe.

This number, however, is based on several unwarranted assumptions. A 40-ply PVDF stave risks suffering differential slippage between layers, hence lowering the amount of actual strain. Also, the 5 cm of deflection (Δy) isn’t realistic, as the bulk of the bending in a shoe sole occurs in a limited area under the metatarsals, hence the strain isn’t distributed evenly along the “1” axis, as assumed in the relations above.

Accordingly, a somewhat more modest piezoelectric insole was developed by a MIT Media Lab team led by Paradiso. The stave was a 10-cm long, truncated diamond-tapered (to maximize the strain distribution), 16-layer bimorph, with eight 28 μ m PVDF sheets laminated on either side of a 1 mm neutral plastic insert, that fit into a men’s US size 11 $\frac{1}{2}$ shoe (see Figure 7). The actual device was seen to produce peak powers into a matched resistive load (empirically found to be 250 $K\Omega$) of roughly 15 mW at heel up and slightly less at toe off; over the course of a 1 step/second per leg standard walk, the average power was 1.3 mW [113]. If we plug the parameters that define this stave into the relation above, but assume a maximum bending deflection of 7 mm (appropriate when we consider the limited area over which strain is applied), we obtain a peak power prediction of $P_{peak} = 16$ mW with the 250 $K\Omega$ load used in the actual tests, which matches the experimental results. Note that the above equation predicts an optimum match at 100 $K\Omega$, however, with 50% more power produced. In the experiment, the power was seen to decrease with loads under 200 $K\Omega$, indicating the relevance of other features (e.g., excitation dynamics, leakage, strain distribution effects) that are not properly captured in this model or our assumptions.

This team produced another piezoelectric insert that tapped into heel strike dynamics. This generator was a unimorph, with a flexible piezoceramic composite laminated on a curved piece of spring steel (manufactured as the *Thunder*TM by Face International) [89] that pressed flat when the heel came down, accordingly straining the piezoelectric material and producing considerably more peak power (60 mW), but due to the brief, impulsive nature of the impact, only 1.8 mW of average power

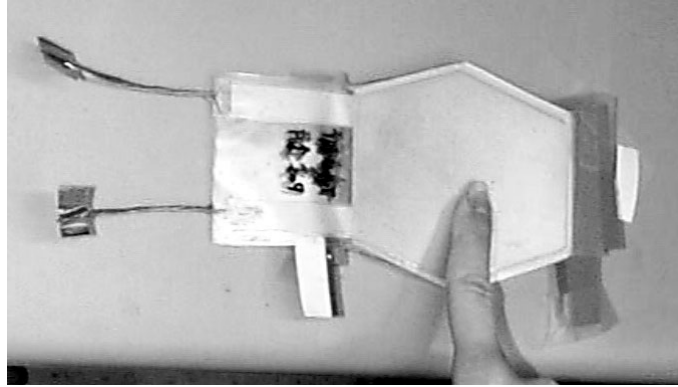

Figure 7: Prototype PVDF bimorph generator for a shoe insole. Power is generated through the mechanical bending of the sole.

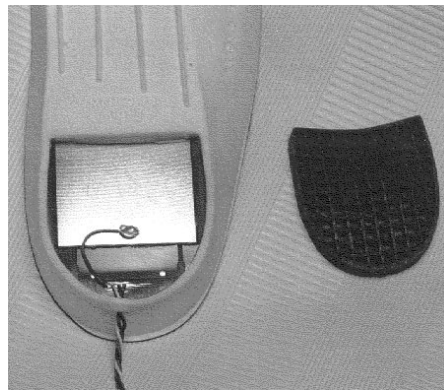

Figure 8: PZT generator embedded in an insole. Power is generated by the user's heel striking (and flattening) the PZT clamshell.

[113]. Shenck and Paradiso [167] subsequently made a clamshell out of two paralleled *ThunderTM* unimorphs placed back-to-back. Again sited under the heel (Figure 8), this generator exhibited 5 mm of displacement and was seen to produce similar peak power, but much better average power across the gait, now gleaming 8.4 mW. Due to the indirect strain applied from bending the fairly stiff neutral element, these systems had very limited mechanical-to-electrical conversion efficiency, of order 1% or less. On the other hand, the generators were worn inside standard jogging sneakers under the insoles, involved essentially no modification to the shoes, and were unnoticeable to the users.

The results given above were for power delivered to a resistor empirically matched to the magnitude of the piezoelectric generator's capacitive impedance for the dynamics of a standard gait. As piezoelectrics are high impedance devices, the voltages tend to be very large (e.g., up to hundreds of volts) and currents very small (e.g., hundreds of μA). In order to power useful electronics, these values must be efficiently transformed to 3-5 volts with currents of milliamperes or more (e.g., the impedance must be lowered). The original study of Paradiso and collaborators [113] used a simple system that full-wave-rectified the generator's signal, then directly applied it directly to a tank capacitor (several orders of magnitude larger than the piezoelectric's capacitance) to accumulate charge. When enough voltage (at least 12 Volts) appeared across this capacitor, a 5-volt series regulator was activated, powering a load until the tank capacitor's voltage dropped below 5 volts. Although this didn't make an efficient match to the piezoelectric source, it produced enough power after 4-5 steps to operate a digital encoder and short-range RF transmitter. Each shoe would then broadcast several cycles of a 12-bit ID code to the vicinity, enabling the wearer to be wirelessly tracked as they moved about; an application originally served by battery-powered IR-transmitting badges at the dawn of Ubiquitous Computing in the early 90's [187].

Other power conversion techniques can be significantly more efficient. As stored power is linearly proportional to capacitance, but proportional to the square of voltage, there's a large gain in not loading the piezoelectric source until it attains its maximum potential. One approach [171] involves switching the tank capacitor into the piezoelectric source only at its

peak voltage, avoiding such inefficiency from continuous capacitive loading. Another approach involves introducing a series inductor to match the piezoelectric's capacitance, producing a LC resonance at the frequency of excitation. For the Hz-level frequencies produced by walking, however, the required inductor would be impractically massive. Exploitation of a synchronous technique [42], that switches the inductor across the piezoelectric element at the extremes of its voltage swing, can gate a higher frequency LC resonance to be synchronized to a much lower frequency stimulation (such as from walking) and make the power conditioning electronics considerably more efficient.

Switching regulators can provide an efficient coupling to the piezoelectric source, and are much more efficient than linear regulators for large potential drops. One must optimize their design, however, for the very low currents and high voltages involved. A forward-switching converter designed by Shenck [166, 167] to condition the power from the piezoelectric clamshell mounted in the heel of a Navy boot achieved a conversion efficiency of 17.6%, better than twice the efficiency of the bucket-capacitor and linear regulator originally used in the original Media Lab study [113]. Researchers are further evolving this approach by exploring adaptive switching regulators for piezoelectric power harvesting that dynamically adjust the switcher's duty cycle to maximize the output current [140].

Other researchers and inventors have embedded rigid piezoelectrics in shoes for power scavenging from the heel strike. As mentioned earlier, materials like PZT have much higher piezoelectric coefficients and can be driven efficiently at resonance, but they are brittle, and as the resonant frequencies of manageable pieces are quite high (e.g., many KHz), the low frequencies of walking must be translated up to this level by a nonlinear mechanism (e.g., modulated hydraulics or mechanical impacts). In 2000, Trevor Baylis and collaborators at the Electric Shoe Company in the UK claimed to have generated 100-150mW of power from heel inserts embedded with a piezoelectric crystal; Baylis demonstrated the system by using it to partially charge a cellular phone battery after a five-day trek through the Namibian Desert [59]. Better-documented shoe generators that drive PZT elements via active and passive hydraulics are described in more detail in Section 12.4.



Figure 9: An electrostatic generator based on compression of a charged dielectric elastomer during heel strike. Prototype implementation in a boot (left) and closeup of the generator (right), showing bellows on bottom and retaining frame on top. Photos courtesy SRI, International.

As part of a Defense Advanced Research Projects Agency (DARPA) initiative on energy harvesting [139], Pelrine, Kornbluh, and collaborators at SRI International have developed electrostatic generators based around materials called electroactive polymers or dielectric elastomers [144, 20], which were introduced above in Section 10. Dielectric elastomers, made from components such as silicone rubber or soft acrylics, are extremely compliant - a displacement of 2-6 mm can easily drive these materials to 50-100% area strain, depending on the generator's configuration - hence they're ideal substitutes for the rubbery heel of a running shoe [168], for example. They can also be highly efficient, with a practical device achieving energy densities of 0.2 J/g and calculations indicating a possibility of approaching 1.5 J/g.

The SRI team has built an elastomer generator into the heel of a boot, as shown in Figure 9. The generator's structure can be gleaned from the right photo - an elastomer membrane is mounted between a bellows filled with a fluid or gel and a rigid frame riddled with holes (the wires at either side connect to the electrodes on each face of the elastomer). As indicated in the left photo, the generator is mounted in a hole cut out of the center of a heel made from compliant foam (the foam only supports the prototype generator, which could technically make up the entire heel). Accordingly, when the heel presses down, the bellows compress, applying pressure to the elastomer membrane, which balloons into the holes in the frame, producing strain, hence, when voltage is applied across the electrodes, power. They have achieved an energy output of 0.8 Joules per

step with this boot [112] with a heel compression of only 3 mm (limited by Army footwear specifications), yielding 800 mW of power per shoe at a 2 step/sec pace. Benchtop testing has indicated that the material will last for at least 100,000 cycles, but they believe that improved packaging and design can increase the lifetime to beyond 1 million cycles - enough to meet the required lifetime of commercial footwear. As more compression (up to 5-9 mm) is feasible in a commercial shoe, they anticipate being able to extract 1 W of power, allowing for a 50% voltage conversion (from several kV applied across the elastomer to 3-5 volts that can power standard electronics) and storage efficiency [111].

Finally, to round out this discussion, we consider another type of footwear. Instead of extracting the power generated by a piezoelectric element embedded in or bonded to a structure, it can be applied via simple filtering and conditioning electronics to another piezoelectric element in the same structure [28], or just dissipated into a passive load, in order to damp vibrations and artificially “stiffen” the structure [2]. The first commercial application of such “smart structure” research to hit the mass market has been the K2 ski [119], designed by the MIT spinoff company “Active Control eXperts” (ACX), which uses a piece of piezoceramic inserted between the skiboot attachment and the ski, coupled to passive electronics that damp vibrations. Sufficient power is generated to flash a LED when the ski flexes, yielding a visual indication of the device’s operation [118] (note that, contrary to frequent assumption, the famous flashing sneakers made by companies like “LA Gear” drive the LEDs in their soles by an embedded battery connected to an inertially-triggered tamper switch [190], not via parasitically-extracted power).

12.3 Rotary generator conversion

Through the use of a cam and piston or ratchet and flywheel mechanism, the motion of the heel might be converted to electrical energy through more traditional rotary generators. The efficiency for industrial electrical generators can be very good. However, the added mechanical friction of the stroke-to-rotary converter reduces this efficiency. A normal car engine, which contains all of these mechanisms and suffers from inefficient fuel combustion, attains 25% efficiency. Thus, for the purposes of this section, 50% conversion efficiency will be assumed for this method, which suggests that, conservatively, 17-34 W might be recovered from a “mechanical” generator.

How can this energy be recovered without creating a disagreeable load on the user? **A possibility is to improve the energy return efficiency of the shoe and tap some of this recovered energy to generate power.** Specifically, a spring system, mounted in the heel, would be compressed as a matter of course in the human gait. The energy stored in this compressed spring can then be returned later in the gait to the user. Normally this energy is lost to friction, noise, vibration, and the inelasticity of the runner’s muscles and tendons (humans, unlike kangaroos, become less efficient the faster they run [137]). Spring systems have approximately 95% energy return efficiency while typical running shoes range from 40% to 60% efficiency [168, 10, 90]. Indeed, shoe soles with embedded heel springs have been developed to augment human gait capacity [91]. Volumetric oxygen studies have shown a 2-3% improvement in running economy using such spring systems over typical running shoes [90]. Similarly suggestive are the “tuned” running track experiments of McMahon [130]. The stiffness of the surface of the indoor track was adjusted to decrease foot contact time and increase step length. The result was a 2-3% decrease in running times and seven new world records in the first two seasons of the track. Additionally, a reduction in injuries and increase of comfort was observed. Thus, if a similar spring mechanism could be designed for the gait of normal walking, and a ratchet and flywheel system is coupled to the upstroke of the spring, it may be possible to generate energy while still giving the user an improved sense of comfort. In fact, active control of the loading of the generation system may be used to adapt energy recovery based on the type of gait at any given time.

Although constant-force springs are available and used in products such as clocks, the simplest mechanical springs do not provide constant force over the fall of the heel but rather a linear increase, hence only about half of the calculated energy would be stored on the downstep. An open question is what fraction of the spring’s return energy can be sapped on the upstep while still providing the user with the sense of an improved “spring in the step” gait. Initial mock-ups have not addressed this issue directly, but a modern running shoe returns approximately 50% of the 10J it receives during each compression cycle [168, 10] (such “air cushion” designs were considered a revolutionary step forward over the hard leather standard several decades ago). Given a similar energy return over the longer distance of the spring system, the energy storage of the spring, and the conversion efficiency of the generator, 12.5% of the initial 67 W is harnessed for a total of 8.4 W of available power.

The idea of embedding a spring and rotary generator into the heel of a boot or shoe has not escaped the attention of various inventors. Patents of this ilk date back to the 1920’s and seem to reappear periodically in different incarnations [22, 114, 49]. Paradiso and his team evaluated these ideas by building a prototype shoe attachment with a simple spring, flywheel, and generator system that produced peak powers near 1 Watt (average power roughly 250 mW) while exploiting a 3cm deflection in the fall of the heel during a normal walk (Figure 10); enough power to play loud music from a radio speaker as the user



Figure 10: Rotary generator fit to a shoe for proof-of-concept studies at the MIT Media Lab.

walked about [113]. The mechanical system proved quite obtrusive, however, which brings into doubt how much deflection might be utilized without annoying the user. Hayashida created an improved model with the generator integrated into the sole (Figure 11), yet mechanical wear remained an issue [88]. As rotary generators need to spin rapidly to achieve efficiency, these systems all involve significant gear ratios, which introduce considerable mechanical complexity and fairly high torque, leading to a high probability of breakage. Indeed, a heel-mounted dynamo was developed by Jim Gilbert from the University of Hull for Trevor Baylis' walk through the Namibian Desert; while the piezoelectric insole appeared to last for several days, the mechanical shoe's crankshaft broke after only a few hours of use [59]. A linear motor may provide a simpler mechanical interface to footfalls, hence has been proposed for adaptation to shoe generators [110].

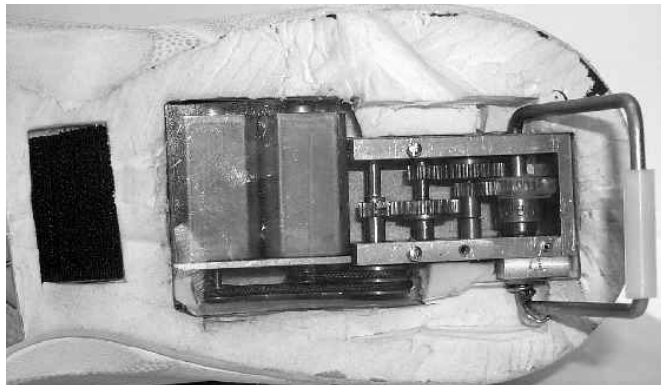

Figure 11: Improved rotary shoe generator, with gearbox and two magnetic generators built into the sole of a sneaker (bottom view).

US Patent #4845338 shows an interesting variant of the mechanical generator idea [115]. The patent describes an “inflatable boot liner with electrical generator and heater.” Footfalls not only generate electricity through a flywheel system to power an electrical resistance heater but also pump air through the boot to distribute the heat. This idea of using footfalls to create fluidic pressure leads to yet another approach to generating power from walking, which we address in the next section.

12.4 Hydraulic and Pneumatic Systems

In 1971, McLeish and Marsh tested a hydraulic pump system in the heel of the user's shoe for powering the user's bionic arm [128]. This system had a relatively small, 0.375-inch throw, which the user reported did not hinder his normal gait. However, this system recovered, on average, 5W of power while the user was walking. While quite impressive in power recovery, one can only imagine that the hydraulic line running up the pants leg chafed! Surprisingly, a separate but similar system was also reported by Marsden and Montgomery in the same volume [125]. Note that such hydraulic systems can also drive a rotary magnetic generator via a turbine [116] or impeller and also provide a means of moving the bulky generator mechanism

away from the highly constrained and hazard-prone neighborhood of the shoe sole [182] without cumbersome mechanical linkages.

Antaki and collaborators presented a shoe-mounted piezoelectric generator in 1995 that was developed for the purpose of powering artificial organs [17]. Their device, which looked like a large platform shoe, incorporated two cylindrical tubes in the insole, each of which housed a PZT stack stimulated by a passive hydraulic pulser-amplifier that converted low-frequency footfall energy into an intense series of high-frequency impulses that drove the PZT at its mechanical resonance. The hydraulic reservoir was differentially compressed during heel strike and toe off, hence power was extracted across the entire gait. Although the prototype was somewhat bulky and heavy, the entire generator was embedded in the shoe, and average powers of 250-700 mW were extracted from walking (depending on the type of gait and weight of the user) and over 2 Watts could be gleaned from a simulated jog.

A more ergonomic version of the concept, also developed under DARPA's Energy Harvesting Program [139], has been explored in Nesbit Hagood's lab at MIT [83, 193]. The heel strike compresses a hydraulic bladder by 8mm. This pressure is then routed through an active valve that chops the fluid flow in order to hammer a PZT stack at its resonant frequency of 20 kHz. As tested in components, the system is 40% efficient and produces 3W of power with three one cubic centimeter PZT units per shoe (these generator chambers are not anticipated to be mounted in the insole, keeping a compact shoe with attached power nodule).

12.5 Getting Off Your Feet

While these systems are still laboratory prototypes, walking seems a fruitful area to exploit for power generation in the future. A significant concern about the overall market penetration of shoe-generator systems, however, is the potential inconvenience of transporting power from the shoes to devices at other parts of the body. Although some researchers have explored sending high-frequency AC current through the body to power wearable electronics [138, 191], safety considerations and coupling limitations can severely restrict the available power. A more scalable possibility, as exploited by Baylis' shoes, is to charge a battery mounted on the shoe itself, which is then moved into the device once charging is complete [59]. This competes with the utility of charging your batteries at home, however, which is certainly simpler unless you're far off the power grid (e.g., backpackers or military deployments). Another possibility is to exploit a network of wires integrated into clothing - certainly an area of interest for researchers in wearable computing [150, 94, 124], but not yet on the fashion racks. A third strategy is to just use the power in a local application sited at the foot. Although inventors seem to love generator-powered boot heaters [114, 115, 49], and several in-situ footwear applications have been demonstrated with lower-power systems (e.g., the self-powered wireless tracking system [113] and the damped ski [119]), new developments, such as the SRI elastomer generators [144] promise an ergonomic package that produces enough power to support a considerable amount of computation. One can perhaps envision central, wearable "Personal Servers"[188] embedded into the footwear, where they glean all the power that they need from their host's ambulation. These servers need no hardwired connection to other devices - they'd communicate wirelessly with peripherals scattered around the body (powered by locally-scavenged energy where appropriate) and the external environment.

13 Conclusion

In the design of mobile electronics, power is one of the most difficult restrictions to overcome, and current trends indicate this will continue to be an issue in the future. Designers must weigh wireless connectivity, CPU speed, and other functionality versus battery life in the creation of any mobile device. Power generation from the user may alleviate such design restrictions and may enable new products such as batteryless on-body sensors. Power may be recovered passively from body heat, arm motion, typing, and walking or actively through user actions such as winding or pedaling. In cases where the devices are not actively driven, only limited power can generally be scavenged (with the possible exception of tapping into heel strike energy) without inconveniencing or annoying the user. That said, as detailed elsewhere in this volume, clever power management techniques combined with new fabrication and device technologies are steadily decreasing the energy needed for electronics to perform useful functions, providing an increasingly relevant niche for power harvesting in mobile systems.

References

- [1] R. Adler, P. Desmares, and J. Spracklen. Ultrasonic remote control for home receivers. *IEEE Transactions on Consumer Electronics*, CE-28(1):123–128, February 1982.
- [2] J.B. Aldrich, N.W. Hagood, A. von Flotow, and D.W. Vos. Design of passive piezoelectric damping for space structures. *Proceedings of the SPIE - Smart Structures and Materials 1993*, 1917(2):692–705, 1993.
- [3] A. Ananthaswamy. Give it some gas. *New Scientist*, 182(2452):26–29, June 19 2004.
- [4] Anonymous. Sandia designs vibe-powered sensor that transforms shakes into electricity. Technical report, Sandia National Laboratory, <http://www.sandia.gov/media/NewsRel/NR2002/vibepoweredsensor.htm>, 2002.
- [5] Anonymous. Energy harvester converts low-level vibrations into usable electricity. Technical report, Ferro Solutions, Inc., http://www.ferrosi.com/files/FS_product_sheet_wint04.pdf, 2004.
- [6] Anonymous. Near Field Communication - Interface and Protocol (NFCIP-1). Technical Report ISO/IEC 18092 and ECMA-340, International Organization for Standardization, Geneva, Switzerland, 2004.
- [7] Anonymous. Miniature radio can be hidden in tooth. *Dental Survey*, 51:45, September 1975.
- [8] Anonymous. Piezo film sensors technical manual. Technical Report 65751, Measurement Specialties (MSI), Inc. (formerly AMP Inc.), Valley Forge, PA, 1995.
- [9] Anonymous. *Piezoelectric Motor/Actuator Kit, Introduction to Piezoelectricity*. Piezo System, Inc., Cambridge, MA, 1995. See: <http://www.piezo.com>.
- [10] Anonymous. Running training section. *Endurance Training Journal*, 1995.
- [11] Anonymous. *Piezoelectric Ceramics: Principles and Applications*. American Piezo Ceramics (APC International), Mackeyville, PA, 2001.
- [12] Anonymous. Turn the handle and talk. *The Economist*, pages 10, Technology Quarterly Section, December 8 2001.
- [13] Anonymous. Power calculator for flash memory. <http://www.micron.com>, 2003.
- [14] Anonymous. Nissho power products. http://www.nseg.co.jp/english/products/line_up.htm, 2004.
- [15] Anonymous. Sidewinder specifications. <http://www.windupradio.com/sidewinder/index.htm>, 2004.
- [16] Anonymous. Vibration-powered hour meters. *McMaster-Carr Catalog*, 110:1423, 2004.
- [17] J.F. Antaki, F.E. Bertocci, E.C. Green, A. Nadeem, T. Rintoul, R.L. Kormos, and B.P. Griffith. A gait powered autologous battery charging system for artificial organs. *ASAIO Journal: Proc. 1995 American Society of Artificial Internal Organs Conf.*, 41(3):M588–M595, July-September 1995.
- [18] A. Applewhite. IT takes a village. *IEEE Spectrum*, 40(9):40–45, September 2003.
- [19] J.U. Martinez Arazia. Wireless transmission of power for sensors in context aware spaces. Master’s thesis, MIT Media Laboratory, June 2002.
- [20] S. Ashley. Artificial muscles. *Scientific American*, 289(4):52–59, October 2003.
- [21] C.J. Bader and R.P. Branco. 3,657,113: System for the generation of electrical power having a spring powered prime mover responsive to output voltage. *US Patent*, November 24 1972.
- [22] J. Barbieri. 1,506,282: Electric shoe. *US Patent*, August 26 1924.
- [23] T. Bartczak and C. Aimone. Around-The-World Music. *Popular Science*, page 28, January 2004.
- [24] O. Bartels. 6,378,360: Apparatus for wire-free transmission from moving parts. *US Patent*, April 30 2002.

- [25] C.A.L. Bassett. Biologic significance of piezoelectricity. *Calcified Tissue Research*, 1:252–272, 1968.
- [26] J.P. Benner and L. Kazmerski. Photovoltaics gaining greater visibility. *IEEE Spectrum*, 26(9):34–42, September 1999.
- [27] B. Berland. Photovoltaic technologies beyond the horizon: Optical rectenna solar cell - Final report, 1 August 2001 - 30 September 2002. Technical Report NREL/SR-520-33263, National Renewable Energy Laboratory (NREL), Golden, Colorado, February 2003.
- [28] A.S. Bicos. 5,315,203: Apparatus for passive damping of a structure. *US Patent*, May 24 1994.
- [29] G. Binyamin, T. Chen, Y.-C. Zhang, and A. Heller. Design and stability of implanted biofuel cell anodes. In R. Nowak, editor, *Proc. of the DARPA Energy Harvesting Program Review*, Washington, D.C., April 13-14 2000. DARPA.
- [30] W. Braune and O. Fischer. *The Human Gait*. Springer-Verlag, Berlin, 1895–1904; reprinted 1987.
- [31] E. Braunwald, editor. *Heart Disease: A Textbook of Cardiovascular Medicine*. W. B. Saunders Company, Philadelphia, 1980.
- [32] H. Bray. Your next battery: a fuel cell? *The Boston Globe*, pages F1,F5, November 25 2003.
- [33] R.H. Brown. The LED report. Technical report, MSI, Piezo Sensors Division, Valley Forge, PA, http://www.msiusa.com/download/pdf/english/piezo/RB_EG_05.pdf, September 2 1987.
- [34] R.H. Brown. Energy generation using piezo film (I). Technical report, MSI, Piezo Sensors Division, Valley Forge, PA, http://www.msiusa.com/download/pdf/english/piezo/RB_EG_01.pdf, 1991.
- [35] R.H. Brown. Energy generation using piezo film (II). Technical report, MSI, Piezo Sensors Division, Valley Forge, PA, http://www.msiusa.com/download/pdf/english/piezo/RB_EG_02.pdf, 1991.
- [36] R.H. Brown. Power generation using PVDF on a credit-card. Technical report, MSI, Piezo Sensors Division, Valley Forge, PA, http://www.msiusa.com/download/pdf/english/piezo/RB_EG_04.pdf, July 27 1998.
- [37] R.H. Brown. Energy generation using piezo film (III) - thermal destruction of piezo film. Technical report, MSI, Piezo Sensors Division, Valley Forge, PA, http://www.msiusa.com/download/pdf/english/piezo/RB_EG_03.pdf, September 14 1999.
- [38] W.C. Brown. The history of power transmission by radio waves. *IEEE Trans. Microwave Theory Tech., Special Centennial Historical Issue*, MTT-32(9):1230–1242, September 1984.
- [39] R. Buder. *The Invention That Changed the World: How a Small Group of Radar Pioneers Won the Second World War and Launched a Technical Revolution*. Simon & Schuster - Touchstone Books, New York, 1997.
- [40] A. Van Buren. Dear Abby - Yet another reason to floss regularly. *Chicago Tribune Magazine*, page 36, October 18 1988.
- [41] T. Büren, P. Lukowicz, and G. Tröster. Kinetic energy powered computing - an experimental feasibility study. In *ISWC*, pages 22–24, 2003.
- [42] J.R. Burns, P. Smalser, G.W. Taylor, and T.R. Welsh. 6,528,928: Switched resonant power conversion electronics. *US Patent*, March 4 2003.
- [43] W. Cady. *Piezoelectricity*. Dover Publishers, Inc., New York, 1964.
- [44] Edgar Callaway. *Wireless Sensor Networks: Architectures and Protocols*. CRC Press LLC, Boca Raton, FL, 2004.
- [45] C.B. Carroll. 5,814,921: Frequency multiplying piezoelectric generators. *US Patent*, September 29 1998.
- [46] A. Chandrakasan, R. Amirtharajah, S. Cho, J. Goodman, G. Konduri, J. Kulik, W. Rabiner, and A. Wang. Design considerations for distributed microsensor systems. In *IEEE 1999 Custom Integrated Circuits Conference*, pages 279–286. IEEE, May 1999.

- [47] J. Chang and L. Tassiulas. Energy conserving routing in wireless ad-hoc networks. In *INFOCOM (1)*, pages 22–31, 2000.
- [48] A. Chapuis and E. Jaquet. *The History of the Self-Winding Watch*. Roto-Sadag S.A., Geneva, 1956.
- [49] S-H. Chen. 5,495,682: Dynamoelectric shoes. *US Patent*, March 5 1996.
- [50] M. Cheney. *Tesla: Man Out of Time*. A Laurel Book, Dell Publishing Co., New York, 1981.
- [51] N. Ching, H. Wong, W. Li, P. Leong, and Z. Wen. A laser-micromachined multi-modal resonating power transducer for wireless sensing systems. In *Sensors and Actuators, A: Physical*, volume 97–98, pages 685–690, April 2002.
- [52] D.L. Churchill, M.J. Hamel, C.P. Townsend, and S.W. Arms. Strain energy harvesting for wireless sensor networks. *Proceedings of the SPIE - Smart Structures and Materials 2003*, 5055:319–327, March 2003.
- [53] J.H. Comroe. *Physiology of Respiration, 2'nd Edition*. Year Book Medical Publishers, Chicago, 1979.
- [54] M. Cooper. Batteries not included. *New Scientist*, 171(2307):24, September 24 2001.
- [55] A. Crisan. 5,911,529: Typing power. *United States Patent*, June 1999.
- [56] L.R. Crump. 2,813,242: Powering electrical devices with energy abstracted from the atmosphere. *US Patent*, November 12 1957.
- [57] H.R. Van Deventer. 1,184056: Self-contained generating and lighting unit. *US Patent*, May 23 1916.
- [58] R.S. DiMatteo, P. Greiff, S.L. Finberg, K.A. Young-Waithe, H.K.H. Choy, M.M. Masaki, and C.G. Fonstad. Micron-gap thermophotovoltaics (MTPV). In *Proc. of the Fifth Conference on Thermophotovoltaic Generation of Electricity (Rome, Italy)*, pages 232–240, Melville, NY, September 16-19 2002. AIP Conference Proceedings (No. 653).
- [59] J. Drake. The greatest shoe on earth. *Wired*, 9(2):90–100, February 2001.
- [60] C.K. Dyer. Fuel cells for portable applications. *Journal of Power Sources*, 106(1-2):31–34, 2002.
- [61] T. Eggborn. Analytical models to predict power harvesting with piezoelectric materials. Master's thesis, Virginia Polytechnic Institute and State University, Blacksburg, VA, May 2003.
- [62] M. El-hami, P. Glynn-Jones, N. White, M. Hill, S. Beeby, E. James, A. Brown, and J. Ross. Design and fabrication of a new vibration-based electromechanical power generator. *Sensors and Actuators, A: Physical*, 92(1-3):335–342, August 2001.
- [63] A.H. Epstein. Millimeter-scale, MEMS gas turbine engines. In *American Society of Mechanical Engineers, International Gas Turbine Institute, Turbo Expo (Publication) IGTI*, pages 669–696, Atlanta, Georgia, June 16-19 2003. ASME.
- [64] M. Feldmeier and J.A. Paradiso. Giveaway wireless sensors for large-group interaction. In *Human Factors in Computing Systems (CHI 2004 Proceedings) - Extended Abstracts*, pages 1291–1292, Vienna, Austria, April 27-29 2004. ACM Press.
- [65] K. Finkensteller. *RFID Handbook: Fundamentals and applications in contactless smart cards and identification*. John Wiley & Sons, New York, 2003.
- [66] J.-P. Fleurial, T. Olson, A. Borschevsky, T. Caillat, E. Kolawa, M. Ryan, and W. Philips. 6,288,321: Electronic device featuring thermoelectric power generation. *United States Patent*, January 2001.
- [67] J.-P. Fleurial, M. Ryan, A. Borschevsky, W. Phillips, E. Kolawa, J. Snyder, T. Caillat, T. Kascich, and P. Mueller. 6,388,185: Microfabricated thermoelectric power-generation devices. *United States Patent*, May 2002.
- [68] J.-P. Fleurial, G.J. Snyder, J.A. Herman, M. Smart, P. Shakkottai, P.H. Giauque, and M.A. Nicolet. Miniaturized thermoelectric power sources. In *Proc. of the 34th Intersociety Energy Conversion Engineering Conference*, pages Paper 1999–01–2569, Vancouver, BC, Canada, August 2-5 1999. Society of Automotive Engineers.

- [69] R.L. Forward. Starwisp: An ultralight interstellar probe. *Journal of Spacecraft and Rockets*, 22(3):345–350, 1985.
- [70] K.R. Foster, L.S. Erdreich, and J.E. Moulder. Weak electromagnetic fields and cancer in the context of risk assessment. *Proceedings of the IEEE*, 85(5):733–746, May 1997.
- [71] J. Fraden. *Handbook of Modern Sensors, Third Edition*. Springer Verlag, Berlin, 2004.
- [72] K. Fu, A.J. Knobloch, F.C. Martinez, D.C. Walther, C. Fernandez-Pello, A.P. Pisano, and D. Liepmann. Design and fabrication of a silicon-based MEMS rotary engine. *ASME, Advanced Energy Systems Division (Publication) AES*, 41:303–308, 2001.
- [73] J. Gillies, editor. *A Textbook of Aviation Physiology*. Pergamon Press, Oxford, 1965.
- [74] B. Gilomen and P. Schmidli. Mouvement á quartz dame dont l’énergie est fournie par une génératrice, calibre ETA 204.911. In *Congr s Europ en de Chronom trie*, Geneva, September 2000.
- [75] P. Glaser. Power from the sun; its future. *Science*, 162(22):857–861, November 1968.
- [76] E.G. Gonzalez and P.J. Corcoran. Energy expenditure during ambulation. In J.A. Downey, S.J. Myers, E.G. Gonzalez, and J.S. Lieberman, editors, *The Physiological Basis of Rehabilitation Medicine*, pages 413–446. Butterworth-Heinemann, Boston, MA, 1994.
- [77] G. G rge, M. Kirstein, and R. Erbel. Microgenerators for energy autarkic pacemakers and defibrillators: Fact or fiction? *Herz*, 26(1):64–68, 2001.
- [78] M.A. Green, K. Emery, D.L. King, and W. Warta S. Igari. Solar cell efficiency tables (Version 22). *Progress in Photovoltaics: Research and Applications*, 11:347–352, 2003.
- [79] S. Griffith. Bettery homepage. <http://web.media.mit.edu/~saul/bettery/index.htm>, 2004.
- [80] S. Griffith. E-mail correspondence. *MIT Media Laboratory*, February 22 2004.
- [81] H. Guo and A. Lal. Nanopower betavoltaic microbatteries. In *Proceedings of Transducers ’03*, volume 1, pages 36–39, Boston, MA, June 8-12 2003. IEEE Press.
- [82] P.L. Hagelstein and Y. Kucherov. Enhanced figure of merit in thermal to electrical energy conversion using diode structures. *Physics Letters*, 81(3):559–561, July 15 2002.
- [83] N. Hagood, D. Roberts, L. Saggere, M. Schmidt, M. Spearing, K. Breuer, R. Mlcak, J. Carretero, F. Ganji, H. Chen, Y. Su, and S. Pulitzer. Development of micro-hydraulic transducer technology. In *Intl. Conf. Adaptive Structures and Technologies*, pages 91–102, Lancaster, PA, 1999. Technomic Publishing.
- [84] D. Halliday, R. Resnick, and K. Krane. *Physics, vol. 1 & 2 extended, 4th edition*. Wiley & Sons Inc., New York, 1992.
- [85] D. Halvorsen. Private correspondence. *AMP Inc.*, May 1995.
- [86] W.G. Harris. *Lucy & Desi: The Legendary Love Story of Television’s Most Famous Couple*, page 113. Simon & Schuster, New York, hardcover edition, 1991.
- [87] E. H usler, L. Stein, and G. Harbauer. Implantable physiological power supply with PVDF film. *Ferroelectrics*, 60:277–282, 1984.
- [88] J. Hayashida. Unobtrusive integration of magnetic generator systems into common footwear. *Bachelor’s Thesis, MIT Department of Mechanical Engineering*, 2000.
- [89] R.F. Hellbaum, R.G. Bryant, and R.L.Fox. 5,632,841: Thin layer composite unimorph ferroelectric driver and sensor. *US Patent*, May 27 1997.
- [90] H. Herr. Private correspondence. *MIT Leg Laboratory*, April 1996.

- [91] H.M. Herr and R.I. Gamow. 6,029,374: Shoe and foot prosthesis with bending beam spring structures. *US Patent*, February 29 2000.
- [92] J. Hogan. Now we can soak up the rainbow. *New Scientist*, 176(2372):24, December 7 2002.
- [93] R. Holland and E. EerNisse. *Design of Resonant Piezoelectric Devices (Research Monograph no. 56)*. MIT Press, Cambridge, MA, 1969.
- [94] A.P.J. Hum. Fabric area network: a new wireless communications infrastructure to enable ubiquitous networking and sensing on intelligent clothing. *Computer Networks*, 35(4):391–399, 2001.
- [95] J. Hutchinson. History and status of personal power devices for the commercial market. In M. Rose, editor, *Prospector IX: Human-Powered Systems Technologies*, pages 201–210, Auburn, AL, November 1997. Space Power Institute, Auburn Univ.
- [96] J.E. Hutchinson and P. Becker. 6,472,846: Power source. *US Patent*, October 29 2002.
- [97] W.U. Huynh, J.J. Dittmer, and A.P. Alivisatos. Hybrid nanorod-polymer solar cells. *Science*, 295:2425–2427, March 29 2002.
- [98] E. James, M. Tudor, S. Beeby, N. Harris, P. Glynn-Jones, J. Ross, and N. White. A wireless self-powered micro-system for condition monitoring. In *Euroensors XVI*, Prague, September 2002. Carolina - Euroensors XVI.
- [99] W.B. Spillman Jr., S. Durkee, and W.W. Kuhns. Remotely interrogated sensor electronics (RISE) for smart structures applications. In *Proc. of the SPIE Second European Conference on Smart Structures and Materials (Glasgow UK)*, volume 2361, pages 282–284. SPIE, October 1994.
- [100] T. Kanesaka. Development of a thermal energy watch. In *Société Suisse De Chronométrie*, September 1999.
- [101] N. Karaki and O. Miyazawa. 5,630,155: Portable computer system with mechanism for accumulating mechanical energy for powering the system. *US Patent*, May 13 1997.
- [102] S.C. Kelley, G.A. Deluga, and W.H. Smyrl. Miniature fuel cells fabricated on silicon substrates. *AIChE Journal*, 48(5):1071–1082, 2002.
- [103] J.C. Kendall. Parasitic power collection in shoe mounted devices. *Bachelor's Thesis, MIT Physics Department*, 1998.
- [104] C. Kenneally. Power from the people breaks the hold of batteries and plugs. *New York Times*, page G9, August 3 2000.
- [105] H.-H. Kim, N. Mano, Y. Zhang, and A. Heller. A miniature membrane-less biofuel cell operating under physiological conditions at 0.5 V. *Journal of The Electrochemical Society*, 150(2):A209–A213, 2003.
- [106] P. Kinzie. *Crystal Radio: History, Fundamentals and Design*. Xtal Set Society, Lawrence, Kansas, 1996.
- [107] J. Kistler and M. Satyanarayanan. Disconnected operation in the Coda File System. *ACM Trans. on Computer Systems*, 10(1), February 1992.
- [108] W.H. Ko. 3,456,134: Piezoelectric energy converter for electronic implants. *US Patent*, July 15 1969.
- [109] W.H. Ko. 6,438,193: Self-powered tire revolution counter. *US Patent*, August 20 2002.
- [110] J.A. Konotchick. 5,818,132: Linear motion electric power generator. *US Patent*, October 6 1998.
- [111] R. Kornbluh. E-mail correspondence. *SRI International*, January 6 2004.
- [112] R.D. Kornbluh, R.E. Pelrine, Q. Pei, R. Heydt, S.E. Stanford, S. Oh, and J. Eckerle. Electroelastomers: Applications of dielectric elastomer transducers for actuation, generation and smart structures. In A. McGowan, editor, *Proceedings of the SPIE - Smart Structures and Materials 2002: Industrial and Commercial Applications of Smart Structures Technologies*, volume 4698, pages 254–270. SPIE Press, 2002.

- [113] J. Kymissis, C. Kendall, J. Paradiso, and N. Gershenfeld. Parasitic power harvesting in shoes. In *IEEE Intl. Symp. on Wearable Computers*, pages 132–139, October 1998.
- [114] N. Lakic. 4,674,199: Shoe with internal foot warmer. *US Patent*, June 23 1987.
- [115] N. Lakic. 4,845,338: Inflatable boot liner with electrical generator and heater. *United States Patent*, July 1989.
- [116] N. Landry. 6,201,314: Shoe sole with liquid-powered electrical generator. *United States Patent*, March 2001.
- [117] P.K. Lau and S.M. Peress. 6,650,085: Modular solar battery charger. *US Patent*, November 18 2003.
- [118] K.B. Lazarus and J.W. Moore. D404,100: Ski damper. *US Patent*, January 12 1999.
- [119] K.B. Lazarus, J.W. Moore, R.N. Jacques, F.M. Russo, and R. Spangler. 6,102,426: Adaptive sports implement with tuned damping. *US Patent*, August 15 2000.
- [120] S.J. Lee, A. Chang-Chien, S.W. Cha, R. O’Hayre, Y.I. Park, Y. Saito, and F.B. Prinz. Design and fabrication of a micro fuel cell array with ‘flip-flop’ interconnection. *Journal of Power Sources*, 112:410–418, 2002.
- [121] A. Luzy. 1,472,335: Magneto flash light. *US Patent*, October 30 1923.
- [122] K. Lyons, T. Starner, D. Plaisted, J. Fusia, A. Lyons, A. Drew, and E. Looney. Twiddler typing: One-handed chording text entry for mobile phones. In *Human Factors in Computing Systems (CHI 2004 Proceedings)*, pages 671 – 678, Vienna, Austria, April 27-29 2004. ACM Press.
- [123] E.D. Mantiply, K.R. Pohl, S.W. Poppell, and J.A. Murphy. Summary of measured radiofrequency electric and magnetic fields (10 kHz to 30 GHz) in the general and work environment. *Bioelectromagnetics*, 18(8):563–577, 1997.
- [124] D. Marculescu, R. Marculescu, S. Park, and S. Jayaraman. Ready to ware. *IEEE Spectrum*, 40(10):29–32, October 2003.
- [125] J. Marsden and S. Montgomery. *Human Locomotor Engineering*, chapter Plantar Power for Arm Prosthesis Using Body Weight Transfer, pages 277–282. Inst. of Mechanical Engineers Press, London, 1971.
- [126] J. Martin and C. Piguet. 4,106,279: Wrist watch incorporating a thermoelectric generator. *United States Patent*, August 1978.
- [127] K. Matsuzawa and M. Saka. Seiko human powered quartz watch. In M. Rose, editor, *Prospector IX: Human-Powered Systems Technologies*, pages 359–384, Auburn, AL, November 1997. Space Power Institute, Auburn Univ.
- [128] R. McLeish and J. Marsh. *Human Locomotor Engineering*, chapter Hydraulic Power from the Heel, pages 126–132. Inst. of Mechanical Engineers Press, London, 1971.
- [129] C. McLeod, R. Dickinson, A. Sabkha, and C. Tormazou. Applications for implantable SAW pressure sensors. In G-Z. Yang, editor, *Proc. of the International Workshop on Wearable and Implantable Body Sensor Networks*, pages 22–23, London, April 6-7 2004. Imperial College.
- [130] T. McMahon. *Muscles, Reflexes, and Locomotion*. Princeton University Press, Princeton, NJ, 1984.
- [131] S. Meninger, J.O. Mur-Miranda, R. Amirtharajah, A.P. Chandrakasan, and J.H. Lang. Vibration-to-electric energy conversion. *IEEE Transactions On Very Large Scale Integration (VLSI) Systems*, 9(1):64–76, February 2001.
- [132] R. Min, M. Bhardwaj, S.-W. Cho, N. Ickes, E. Shih, A. Sinha, A. Wang, and A. Chandrakasan. Energy-centric enabling technologies for wireless sensor networks. *IEEE Wireless Communications*, 9(4):28–39, August 2002.
- [133] J.O. Mur Miranda. *Electrostatic Vibration-to-Electric Energy Conversion*. PhD thesis, MIT EECS Department, February 2004.
- [134] P.D. Mitcheson, T.C. Green, E.M. Yeatman, and A.S. Holmes. Architectures for vibration-driven micro-power generators. *IEEE/ASME Journal of Microelectromechanical Systems*, 13(3):429–440, June 2004.

- [135] P.D. Mitcheson, P. Miao, B.H. Stark, A.S. Holmes, and T.C. Green. MEMS electrostatic micro-power generator for low frequency operation. *Sensors and Actuators, Part A*, to appear.
- [136] M. Miyazaki, H. Tanaka, G. Ono, T. Nagano, N. Ohkubo, T. Kawahara, and K. Yano. Electric-energy generation using variable-capacitive resonator for power-free LSI: Efficiency analysis and fundamental experiment. In *Proceedings of the 2003 international symposium on Low power electronics and design (ISLPED '03)*, pages 193–198. ACM Press, August 25-27 2003.
- [137] D. Morton. *Human Locomotion and Body Form*. The Williams & Wilkins Co., Baltimore, MD, 1952.
- [138] B. Nivi. Passive wearable electrostatic tags. Master's thesis, MIT Department of Electrical Engineering and Computer Science, September 1997.
- [139] R. Nowak, editor. *DARPA Energy Harvesting Program Review*, <http://www.darpa.mil/dso/trans/energy/briefing.html>, Washington, D.C., April 13-14 2000. Defense Advanced Research Projects Agency.
- [140] G.K. Ottman, H.F. Hofmann, A.C. Bhatt, and G.A. Lesieutre. Adaptive piezoelectric energy harvesting circuit for wireless, remote power supply. *IEEE Transactions on Power Electronics*, 7(5):669–676, September 2002.
- [141] J. Paradiso and M. Feldmeier. A compact, wireless, self-powered pushbutton controller. In G. Abowd, B. Brumitt, and S. Shafer, editors, *Ubicomp 2001: Ubiquitous Computing*, pages 299–304, Atlanta, GA, September 2001. Springer-Verlag.
- [142] J.A. Paradiso. Renewable energy sources for the future of mobile and embedded computing. In *Invited talk given at the Intel Computing Continuum Conference, San Francisco, California*, Carnegie Mellon University, March 16 2000. Posted at The Universal Library - <http://www.ulib.org>.
- [143] J.A. Paradiso, L.S. Pardue, K-Y. Hsiao, and A.Y. Benbasat. Electromagnetic tagging for electronic music interfaces. *Journal of New Music Research*, 32(4):395–409, December 2003.
- [144] R. Pelrine, R. Kornbluh, J. Eckerle, P. Jeuck, S. Oh, Q. Pei, and S. Stanford. Dielectric elastomers: Generator mode fundamentals and applications. In Y. Bar-Cohen, editor, *SPIE Electroactive Polymer Actuators and Devices*, volume 4329, pages 148–156, Newport Beach, CA, March 2001.
- [145] D. Pescovitz. The power of small tech. *SmallTimes*, 2(1):21–31,51, 2002.
- [146] M. Philipose, K.P. Fishkin, M. Perkowitz, D. Patterson, and D. Haehnel. The probabilistic activity toolkit: Towards enabling activity-aware computer interfaces. Technical Report IRS-TR-03-013, Intel Research, Seattle, WA, December 2003.
- [147] P. Picot. Private correspondence. *Medical Doctor, Robarts Research Institute*, May 1995.
- [148] K. Pistor and F. Schmidt. WO 10/91315 A2: Energy self-sufficient high frequency transmitter. *German Patent*, November 29 2001.
- [149] A. Pohl, R. Steindl, and L. Reindl. The 'intelligent tire': Utilizing passive SAW sensors-measurement of tire friction. *IEEE Transactions on Instrumentation and Measurement*, 48(6):1041–1046, 1999.
- [150] E. Post and M. Orth. Smart fabric, or wearable clothing. In *IEEE Intl. Symp. on Wearable Computers*, pages 167–168, Cambridge, MA, 1997.
- [151] S.S. Pradhan, J. Kusuma, and K. Ramchandran. Distributed compression in a dense microsensor network. *IEEE Signal Processing Magazine*, 19(2):51–60, March 2002.
- [152] H.K. Puharich. 2,995,633: Means for aiding hearing. *US Patent*, August 8 1961.
- [153] V. Raghunathan, C. Schurgers, S. Park, and M.B. Srivastava. Energy-aware wireless microsensor networks. *IEEE Signal Processing Magazine*, 19(2):40–50, March 2002.

- [154] M. Ramsay and W. Clark. Piezoelectric energy harvesting for bio MEMs applications. In *Proc. of SPIE*, volume 4332, pages 429–439, 2001.
- [155] L. M. Reindl, A. Pohl, G. Scholl, and R. Weigel. SAW-based radio sensor systems. *IEEE Sensors Journal*, 1(1):69–78, June 2001.
- [156] T. Riedel. Power considerations for wireless sensor networks. *Sensors*, 21(3):38–41, March 2004.
- [157] S. Ritter. Biofuel cells get smaller. *Chemical & Engineering News*, 79(36):10, 2001.
- [158] N. Rogacheva. *The Theory of Piezoelectric Shells and Plates*. CRC Press, Boca Raton, 1994.
- [159] S. Roundy. *Energy Scavenging with a Focus on Vibration-to-Electricity Conversion for Low Power Wireless Devices*. PhD thesis, University of California, Berkeley - Mechanical Engineering Dept., May 2003.
- [160] S. Roundy, P. Wright, and K. Pister. Micro-electrostatic vibration-to-electricity converters. In *International Mechanical Engineering Congress and Exposition*, pages 487–496, New Orleans, November 17-22 2002. ASME, MEMS Division Publication.
- [161] J. Rabaey S. Roundy, P.K. Wright. A study of low level vibrations as a power source for wireless sensor nodes. *Computer Communications*, 26(11):1131–1144, July 2003.
- [162] I. Sample. Juice on the loose. *New Scientist*, 175(2354):36–38, August 3 2002.
- [163] R.F. Savinell, J.S. Wainright, L. Dudik, and C.C. Liu. Recent advances in microfabricated fuel cells. In *New Materials for Electrochemical Systems IV. Extended Abstracts of the Fourth International Symposium on New Materials for Electrochemical Systems*, pages 371–372, Montreal, Que., Canada, July 9-13 2001. Ecole Polytechnique de Montreal.
- [164] H. Schmidhuber and C. Hebling. First experiences and measurements with a solar powered personal digital assistant (PDA). In *Proceedings of the 17th European Photovoltaic Solar Energy Conference*, pages 658–662, Munich, Germany, October 22-26 2001. WIP.
- [165] A. Schmidt, H.W. Gellersen, and C. Merz. Enabling implicit human computer interaction: A wearable RFID-tag reader. *Proc. of the 2000 IEEE Intl. Symp. on Wearable Computers (ISWC)*, pages 193–194, 2000.
- [166] N.S. Shenck. A demonstration of useful electric energy generation from piezoceramics in a shoe. Master’s thesis, MIT EECS Department, Cambridge, MA, May 1999.
- [167] N.S. Shenck and J.A. Paradiso. Energy scavenging with shoe-mounted piezoelectrics. *IEEE Micro*, 21(3):30–42, May 2001.
- [168] M.R. Shorten. Energetics of running and running shoes. *Journal of Biomechanics*, 26(Suppl. 1):41–51, 1993.
- [169] B. Simes. A ground-noise powered receiver. In P.N. Anderson, editor, *Crystal Sets: The Xtal Set Society Newsletter*, volume 5, pages 66–69, Lawrence, Kansas, 1996. The Xtal Set Society.
- [170] A. Smailagic and R. Martin. Metronaut: A wearable computer with sensing and global communication capabilities. In *IEEE Intl. Symp. on Wearable Computers*. IEEE Computer Society Press, 1997.
- [171] P. Smalser. 5,703,474: Power transfer of piezoelectric generated energy. *US Patent*, December 30 1997.
- [172] D.S. Snyder. 4,510,484: Piezoelectric reed power supply for use in abnormal tire condition warning systems. *US Patent*, April 9 1985.
- [173] T. Starner. The cyborgs are coming. Technical Report 318, Perceptual Computing, MIT Media Laboratory, January 1994.
- [174] T. Starner. Thick clients for personal wireless devices. *IEEE Computer*, 35(1):133–135, January 2002.
- [175] T. Starner, S. Mann, B. Rhodes, J. Levine, J. Healey, D. Kirsch, R. Picard, and A. Pentland. Augmented reality through wearable computing. Technical Report 397, MIT Media Lab, Perceptual Computing Group, Oct 1996.

- [176] J. Stevens. Optimized thermal design of small ΔT thermoelectric generators. In *Proc. of the 34th Intersociety Energy Conversion Engineering Conference*, pages Paper 1999-01-2564, Vancouver, BC, Canada, August 2-5 1999. Society of Automotive Engineers.
- [177] C. Stuart. Powerful year coming in mobile fuel cells. *SmallTimes*, 2(2):60, 2002.
- [178] C. Susskind. *Heinrich Hertz: A Short Life*. San Francisco Press, San Francisco, 1995.
- [179] R. Tashiro, N. Kabei, K. Katayama, Y. Ishizuka, F. Tuboi, and K. Tsuchiya. Development of an electrostatic generator that harnesses the motion of a living body. *Journal of the Japan Society of Mechanical Engineers, Series C*, 43(4):916-922, December 2000.
- [180] N. Tesla. The transmission of electric energy without wires. *Electrical World and Engineer*, XLIII:429-431, March 5 1904.
- [181] J.J. Tiemann. 5,578,877: Apparatus for converting vibratory motion to electrical energy. *US Patent*, November 26 1996.
- [182] E. Tkaczyk. Technology summary. In M. Rose, editor, *Prospector IX: Human-Powered Systems Technologies*, pages 38-43, Auburn, AL, November 1997. Space Power Institute, Auburn Univ.
- [183] M. Toda. Shoe generator: Power generation mechanism. Technical report, AMP Sensors, now the Piezo Sensors Division of MSI, Valley Forge, PA, August 1 1997.
- [184] C.G. Triplett. 4,504,761: Vehicular mounted piezoelectric generator. *US Patent*, March 12 1985.
- [185] S.R. Vektorino, J.V. Platt, and D.A. Springer. 6,220,719: Renewable energy flashlight. *US Patent*, April 24 2001.
- [186] C.B. Vining. Semiconductors are cool. *Nature*, 413:577-578, October 11 2001.
- [187] R. Want, A. Hopper, V. Falcao, and J. Gibbons. The active badge location system. *ACM Transactions on Information Systems*, 10(1):91-102, January 1992.
- [188] R. Want, T. Pering, G. Danneels, and M. Kumar. The Personal Server - changing the way we think about ubiquitous computing. In G. Borriello and L.E. Holmquist, editors, *UbiComp 2002: 4th International Conference on Ubiquitous Computing*, pages 194-209, Berlin and Heidelberg, October 2002. Springer-Verlag.
- [189] J.A. Weaver. A wearable health monitor to aid Parkinson Disease treatment. Master's thesis, MIT Media Lab, June 2003.
- [190] M.C. Tsu W.I. Hwang. 5,396,720: Fixing structure for lightening circuit of 2-stage switch on lightening shoe. *US Patent*, March 14 1995.
- [191] L. Williams, W. Vablais, and S.N. Bathiche. 6,754,472: Method and apparatus for transmitting power and data using the human body. *US Patent*, June 22 2004.
- [192] D. Wren. Private correspondence. *Medical Doctor*, May 1995.
- [193] O. Yaglioglu. Modeling and design considerations for a micro-hydraulic piezoelectric power generator. Master's thesis, MIT EECS Department, Cambridge, MA, February 2002.
- [194] E.M. Yeatman. Advances in power sources for wireless sensor nodes. In G-Z. Yang, editor, *Proc. of the International Workshop on Wearable and Implantable Body Sensor Networks*, pages 20-21, London, April 6-7 2004. Imperial College.
- [195] U. Zechbauer. Neue funkschalter funktionieren ohne strom. *Handelsblatt*, (98):18, May 24-25 2002.